



Guwahati Municipal Corporation

Request for proposal Document (RFP)

Construction, Operation & Maintenance of Modern Public Toilet in campus of the office of the Deputy Commissioner, Kamrup (M), and at Mathgharia under PPP mode

Office of the Commissioner, Guwahati Municipal Corporation,
Panbazaar, Guwahati

Date of issue of Bid Document:	26/02/2016
Date of Pre Bid Meeting:	04/03/2016 at 14.30 hours
Last Date of Submission of Bid Document:	Up to 2.00 pm of 10/03/2016
Date of opening of Bid Document:	10/03/2016 at 2.30 pm

Disclaimer

The information contained in this RFP document provided to the Bidder(s), by or on behalf of Guwahati Municipal Corporation (hereinafter referred to as "GMC" or any of their employees or advisors, is provided to the Bidder(s) on the terms and conditions set out in this RFP document and all other terms and conditions subject to which such information is provided.

The purpose of this RFP document is to provide the Bidder(s) with information to assist the formulation of their Proposals. This RFP document does not purport to contain all the information each Bidder may require. This RFP document may not be appropriate for all persons, and it is not possible for GMC, their employees or advisors to consider the business/investment objectives, financial situation and particular needs of each Bidder who reads or uses this RFP document. Each Bidder should conduct its own investigations and analysis and should check the accuracy, reliability and completeness of the information in this RFP document and where necessary obtain independent advice from appropriate sources. GMC, their employees and advisors make no representation or warranty and shall incur no liability under any law, statute, rules or regulations as to the accuracy, reliability or completeness of the RFP document.

GMC may, in their absolute discretion, but without being under any obligation to do so, update, amend or supplement the information in this RFP document.

**GUWAHATI MUNICIPAL CORPORATION
INVITATIONS FOR PROPOSALS (RFP)
NATIONAL COMPETITIVE BIDDING**

GCS/PMC/678/2015/532

Date:- 25/02/2016

Sealed Tenders are invited for the following works as per details furnished below:-

Sl. No.	Name of Work	Bid Security	Cost of Bid Document	Eligibility Criteria	Date & Time of Submission of Bids
1.	Construction, Operation & Maintenance of Modern Public Toilet at the office campus of the Deputy Commissioner, Kamrup(M)	2% of estimated cost	Rs 5000.00	Refer prequalification criteria in Bid Document	10/03/2016 up to 2.00 PM
2.	Mathgharia in Guwahati Municipal Corporation area under PPP mode				

The detailed Bid document can be downloaded from Website <http://www.gmcportal.in> from 26/02/2016. A document fee of Rs. 5000/- shall be paid in the form of demand draft in favour of Commissioner, Guwahati Municipal Corporation. Otherwise downloaded Tender document shall not be considered. Earnest money deposit will be 2% of the estimated cost for each in the form of Demand Draft/banker's cheque. RFP must be dropped in the tender box kept in the Office of the Commissioner, Chief Engineer Branch, Guwahati Municipal Corporation, Panbazar, Guwahati -781001 on or before 1400 hours on – 10/03/2016 and the opening of tenders will be on 10/03/2016 at 14.30 hours. Other details can be seen in the RFP documents.

**s.d/-
Commissioner,
Guwahati Municipal Corporation
Guwahati**

Memo No: - GCS/PMC/678/2015

Date: __/__/2016

Copy to: -

1. Sri A.L. Gyani, IAS, Additional Commissioner, GMC, for information.
2. The Chief Engineer I and Chief Engineer II, GMC, for information.
3. The M.S, Guwahati Municipal Corporation, for appraisal to the Honourable Mayor and members of Mayor-in-Council, GMC.
4. The Chief Accounts and Audit Officer, GMC, for information.
5. The Divisional Engineer, Div-I, II, III, IV, V &VI for wide circulation.
6. Sri Bhubaneswar Das, Office Assistant, PMC, for making arrangement of uploading the RfP in the GMC website.
7. The M/S Exclusive Advertisement, for publication of the above tender notice in one issue of The Assam Tribune, and "Aamar Asom" with a request for submission of the bills to the undersigned for payment.
8. Sri Deben Ingjal, Superintendent CE Branch & In-charge, Tender Room, for information and necessary action.
9. Notice board.

**s.d/-
Commissioner,
Guwahati Municipal Corporation
Guwahati**

SCHEDULE OF BIDDING PROCESS

GMC would endeavour to adhere to the following schedule from the date of issue of notification during the Bidding Process:

Events	Date
Downloading of the RFP document	26/02/2016
Last date for Pre bid queries to be submitted by the bidders in sealed covers/ e-mailed to guwahaticom@gmail.com	03/03/2016
Response to Queries (Prebid meeting)	04/03/2016 at 2.30 P.M
Tender Due Date / last date for submission of the RFP	10/03/2016 upto 2.00 P.M.
Opening of Technical bid	10/03/2016 at 2.30 P.M.
Opening of Financial bid	To be notified later.
Place of opening of Technical bid and Financial bid	Office of the Commissioner, Guwahati Municipal Corporation, Panbazar, Guwahati-1
Address for communication	Office of the Commissioner, Guwahati Municipal Corporation, Panbazar, Guwahati-1



**Office of the Commissioner:: Guwahati Municipal Corporation
:: Guwahati:: Panbazar :: Guwahati-781001 ::**

Invitation for Bids.

Guwahati Municipal Corporation is responsible for management of public utilities in the city of Guwahati. In this context Guwahati Municipal Corporation intends to issue Request for Proposal for selection of agency for construction and maintenance of modern public toilets in the city of Guwahati.

1. Guwahati Municipal Corporation invites Proposals from eligible bidders for construction & maintenance of modern public toilet in selected location
2. Softcopy of the RFP documents may be obtained from the Project Management Cell office of Guwahati Municipal Corporation, Nabin Bhawan, Aambari Lamb Road, Guwahati 781001 from 26/02/2016. A fee of Rs. 5000/- shall be paid in the form of demand draft in favour of Commissioner, Guwahati Municipal Corporation. Otherwise downloaded Tender document shall not be considered.
3. Earnest money of 2% of the estimated cost to be submitted in demand draft/banker's cheque.
4. RFP must be dropped in the drop box placed in the office of the Commissioner, Chief Engineer Branch, Guwahati Municipal Corporation, Panbazaar, Guwahati -781001 on or before 1400 hours on - 10/03/2016 and the opening of tenders will be on 10/03/2016 at 14.30 hours.
5. Other details can be seen in the RFP documents.

s.d./-

Commissioner

Guwahati Municipal Corporation

Panbazaar, Guwahati- 1

Instructions to Bidder

1. GMC intends to adopt a single stage two cover system bidding process for selection of an agency for construction & maintenance of modern public toilets at selected locations within Guwahati Municipal Corporation area. The agency will maintain the public toilet after construction for a period of ten years. The agency will carry out the following activities:
 - a. Construction of modern public toilet as per approved design by Guwahati Municipal Corporation
 - b. Maintenance of the public toilet upto the satisfaction of Guwahati Municipal Corporation for a period of 10 years
 - c. Handover the created asset to Guwahati Municipal Corporation after 10 years.

The detailed scope of work for all the activities indicated above (“the Service Contract”) is provided in clause 16.

1.1 Each Bidder shall submit a maximum of one (1) Proposal for each location of toilet complex, in response to this RFP Document. Any Bidder who submits more than one Proposal for one location of toilet complex will be disqualified. The work will be awarded to the successful bidders based on their technical and financial capability. The Bidder shall need to demonstrate their technical and financial capacity for carrying out the service. Financial bids of only those bidders will be opened who will be found technically eligible.

1.2 The Bidder shall also be responsible and shall pay for all of the costs associated with the preparation of its Proposal and its participation in the bidding process.

2. Clarification of RFP documents

2.1 A prospective Bidder requiring any clarification of the RFP documents may submit their queries on or before 03/03/16 to Commissioner, Guwahati Municipal Corporation through e-mail at guwahaticom@gmail.com or by submitting a hard copy addressed to the Commissioner GMC. GMC will respond to any request for clarification on the Pre-Bid meeting to be held on 04/03/16.

3. Pre-Bid meeting:

3.1 The Bidder or his official representative is invited to attend a pre-bid meeting which will take place at the office of the Commissioner, Guwahati Municipal Corporation, Chief Engineer Branch, Panbazar, Guwahati-781001 on 04/03/2016 at 14.30 hours.

3.2 The purpose of the meeting will be to clarify issues and to answer questions on any issues that may be raised at that stage.

3.3 The bidder is should mail their queries to guwahaticom@gmail.com or in writing to the undersigned on or before 03/03/2016.

3.4 Minutes of the meeting, including the texts of the questions raised (without identifying the source of enquiry) and the responses given will be uploaded in the GMC website.

3.5 Non-attendance at the pre-bid meeting will not be a cause for disqualification of a bidder, but no claims, whatsoever, from the absentee bidders shall be entertained later on.

4. Amendment of RFP documents

4.1 Before the deadline for submission of Bids the GMC may modify the RFP documents by issuing addendum.

4.2 Any addendum thus issued shall be part of the RFP documents and shall be communicated through GMC website

4.3 To give prospective Bidders reasonable time in which to take an addendum into account in preparing their Bids, the GMC shall extend as necessary the deadline for submission of Bids.

5. Preparation of Bid Documents:

5.1 Documents comprising the Bid:

5.1.1 The Bids comprises of two parts viz Key Submissions and Financial proposal and shall contain the documents as follows

a. Key Submissions: The Bidder would provide all the information as per Clause 5.2 below. GMC would evaluate only those Proposals that are received in the required format and are complete in all respects.

b. Financial proposal shall be the financial offer made by the Bidder for the Service Contract

5.2 Key Submissions:

a. Covering letter in the format set out in Annexure I,

b. Details of the Bidder in the format set out in Annexure II,

c. Anti-collusion certificate in the format set out in Annexure III

d. Proof of Eligibility in the format set out in Annexure IV

e. EMD – in the form of DD in favour of Commissioner, Guwahati Municipal Corporation

5.2.1 Financial Offer: Financial Offer for the Service contract as set in out Annexure V

5.2.2 The contract shall be for the whole works as described in Scope of work

5.2.3 All duties, taxes, and other levies payable by the Successful Bidder under the contract, or for any other cause, shall be included in the financial offer submitted by the Bidder.

5.2.4 And any other materials required to be completed and submitted by the Bidders is in accordance with these instructions.

5.2.5 The bidder has to put his initials/signature in each and every page of the submitted bid document.

6. Proposal validity:

6.1 The Proposal shall remain valid for a period not less than 90 days from the RFP Due Date (Proposal Validity Period). GMC reserves the right to reject any Bid, which does not meet this requirement.

6.2 In exceptional circumstances, prior to expiry of the original time limit, GMC may request that the Bidder may extend the period of validity for a specified additional period. The request and the Bidder's responses shall be made in writing. A Bidder may refuse the request without forfeiting his earnest money deposit. A Bidder agreeing to the request will not be required or permitted to modify his Bids, but will be required to extend the validity of his earnest money deposit for a period of the extension.

7. Earnest Money Deposit (EMD)

7.1 The Bidder shall pay an Earnest Money Deposit (EMD) amount of

- a) Rs. 30,245.00 for the toilet block at the office campus of the Office of the Deputy Commissioner, Kamrup (M).
- b) Rs 38,700.00 for the toilet block at Mathgharia

7.2 The Bidder shall pay the EMD in the form of Demand Draft to be drawn in favour of **Commissioner, Guwahati Municipal Corporation Payable at Guwahati**. EMD amount will have to be submitted by the Bidder taking into account the following conditions:

a. EMD will be accepted only in the form of demand draft or banker's cheque.

7.3 Any Bid not accompanied by an acceptable earnest money deposit and not secured as indicated in Sub-Clauses 7.2 above shall be reject by the GMC as nonresponsive.

7.4 The EMD of unsuccessful Bidders will be returned without any interest as promptly as possible on acceptance of the Bid of the selected Bidder or when the bidding process is cancelled by GMC.

7.5 The EMD of the successful Bidder will be discharged when the Bidder has signed the Agreement and furnished the required Performance Security.

7.6 The EMD may be forfeited:

- a. If the Bidder withdraws the Bid after RFP opening during the period of RFP validity;
- b. If the Bidder does not accept the correction of the RFP Price, pursuant to Clause correction of error.
- c. In the case of a successful Bidder, if the Bidder fails within the specified time limit to
 - i) Sign the Agreement; or
 - ii) Furnish the required Performance Security.

8. Submission of Bids

8.1 The original proposal, both technical and Financial Proposals shall contain no interlineations or overwriting, except as necessary to correct errors made by the Consultants themselves. The person who signed the proposal must initial such corrections.

8.2 An authorized representative of the Consultants shall initial all pages of the Technical and Financial Proposals.

8.3 The Technical Proposal shall be placed in a sealed envelope clearly marked "TECHNICAL PROPOSAL" Similarly, the Financial Proposal shall be placed in a sealed envelope clearly marked "FINANCIAL PROPOSAL" followed by the name of the Assignment/job. The envelopes containing the Technical Proposals, Financial Proposals, EMD shall be placed into an outer envelope and sealed. This outer envelope shall bear the submission address, reference number be clearly marked "DO NOT OPEN, BEFORE (date) 10/03/2016". GMC shall not be responsible for misplacement, loss or premature opening if the outer envelope is not sealed and/or marked as stipulated. This circumstance may be case for Proposal rejection. If the Financial Proposal is not submitted in a separate sealed envelope duly marked as indicated above, this will constitute grounds for declaring the Proposal nonresponsive.

8.4 The Proposals must be dropped in the tender drop box placed in the office of the Commissioner, Chief Engineer branch no later than the time and the date indicated in the RFP, or any extension to this date as per clause 6.2. Any proposal received by the GMC after the deadline for submission shall be returned unopened.

9. Modification of Bids

9.1 Once the Bid is submitted the bidders are not allowed to modify any parts of the Bid

10. RFP opening and evaluation

10.1 GMC shall open the of Key submissions of those Bids that are found to be responsive as provided in Clause 13.3 and undertake evaluation of the Technical Proposals to determine the qualified Bidders.

11. Process to be confidential

11.1 Information relating to the examination, clarification, evaluation, and comparison of RFPs and recommendations for the award of a contract shall not be disclosed to Bidders or any other persons not officially concerned with such process until the award to the successful Bidder has been announced. Any effort by a Bidder to influence the GMC's processing of RFPs or award decisions may result in the rejection of his Bid.

12. Clarifications

12.1 GMC would open the Key Submission of the Proposals on 10/03/2016 at 14.30 hours or any earliest convenient working day after the RFP Due Date for the purpose of evaluation, however not later than eight days from the RFP Due Date. The GMC will open the Key Submissions of all the Bidders received in the presence of the Bidders or their representatives who choose to attend on the date and place specified in the Schedule of Bidding process. The Financial Offers of the

technically qualified Bidders will be opened after intimation of the date, time and venue of such openings to the qualified bidders.

12.2 GMC reserves the right to reject any Bid which does not contain the information/documents as set out in this RFP document.

12.3 To facilitate evaluation of Bids, GMC may, at its sole discretion, seek clarifications in writing from any Bidder.

13. Evaluation

13.1 The criteria for eligibility & qualification of Bidders are set out in Annexure IV.

13.2 As part of the evaluation, the Bids shall be checked for responsiveness with the requirements of the RFP document and only those Bids which are found to be responsive would be further evaluated in accordance with the criteria set out in this RFP document.

13.3 The Bid would be considered to be responsive if it meets the following conditions:

- a. It contains all the information and documents as requested in the RFP document.
- b. It contains information in formats specified in this RFP document.
- c. It mentions the validity period as set out in Clause 6
- d. It provides information in reasonable detail. (“Reasonable Detail” means that, but for minor deviations, the information can be reviewed and evaluated by GMC without communication with the Bidder). GMC reserves the right to determine whether the information has been provided in reasonable detail.
- e. There are no inconsistencies between the Bid and the supporting documents
- f. A Bid that is substantially responsive is one that conforms to the preceding requirements without material deviation or reservation. A material deviation or reservation is one
 - i) which affects in any substantial way, the scope, quality, or performance of the Service contract, or
 - ii) which limits in any substantial way, inconsistent with the RFP Document, GMC’s rights or the Bidder’s obligations under the Agreement, or
 - iii) Which would affect unfairly the competitive position of other Bidders presenting substantially responsive Proposals

13.4 The financial bid of the responsive and qualified bidders shall be checked for adequacy of methodology and operations. GMC may seek clarifications in writing from any bidder regarding its financial bid. GMC shall open the financial offers of only those bidders for evaluation, whose financial bid is found to be adequate in addition to the bidder’s technical eligibility.

13.5 The Financial Offers of only the bidders, who meet the requirements of the Technical Proposal set out in Annexure IV would be opened.

13.6 GMC may in its discretion decide the order of Packages for opening of Financial Offer. Based on the technical and financial capability of the bidder the packages will be opened.

13.7 The Bidder making the highest participatory contribution towards the cost of construction of the toilet above the minimum reserve price would be declared as the Preferred Bidder if he satisfies clause 1.1 of RFP.

13.8 In case there are two or more Bidders quoting the same Financial Offer, GMC in such case may declare the bidder with the higher technical score as the Preferred Bidder.

15.9 GMC reserves the right to reject any Bid, if:

- a. at any time, a material misrepresentation is made or discovered; or
- b. The Bidder does not respond promptly and diligently to requests for supplemental information required for the evaluation of the Proposal.

15.10 Minimum Reserve price

GMC will keep a minimum reserve price towards participatory contribution to the project cost for each location based on the cost estimate.

For Example:

Name of the Location:

- a) Office campus of the Deputy Commissioner, Kamrup (M)
Project Cost: Rs 15,12,250.00
Minimum Reserve price : Rs. 6,04,900.00 (40% of total project cost)
- b) Mathgharia,
Project Cost : Rs 19,34, 600.00
Minimum Reserve price : Rs. 7,73,840.00 (40% of total project cost)

Bid offer in terms of, **Participatory contribution as % of the project cost:** Should be higher than the minimum reserve price (40% of total project cost) *i.e.*, more than **Rs. 6,04,900.00** for the site at the Office campus of the Deputy Commissioner, Kamrup (M) and more than **Rs. 7,73,840.00** for the site at Mathgharia

The bidder who will quote the highest % of the contribution towards the project cost will be the preferred bidder.

15.11 Correction of errors

15.11.1 Bids determined to be substantially responsive will be checked by the GMC for any arithmetic errors, if there is a discrepancy between the rates in figures and in words; the lower of the two will govern.

15.11.2 In the event of acceptance of the Preferred Bidder, GMC shall declare the Preferred Bidder as the Successful Bidder. GMC will notify the Successful Bidder through a Letter of Award (LoA) that its Bid has been accepted.

15.11.3 The Successful Bidder shall start the construction work within 15 days of the receipt of the letter of acceptance, failing which, the award will be cancelled and the EMD will be forfeited.

15.11.4 The Successful Bidder shall execute the Agreement immediately after producing the above requirement.

15.11.5 The Successful Bidder shall also furnish Performance Security by way of an irrevocable Bank Guarantee, issued by a nationalized bank or a scheduled bank located in India in favour of The Commissioner, Guwahati Municipal Corporation as required under the Agreement for an amount of 2% of the G.M.C. contribution and valid for the entire contract period of 18 months and 3 month thereafter.

15.11.6 Notwithstanding anything contained in this RFP document, GMC reserves the right to accept or reject any Bid, or to annul the bidding process or reject all Bids, at any time without

any liability or any obligation for such rejection or annulment, without assigning any reasons thereof.

16. Scope of Work & Terms & conditions

16.1. Location

Guwahati Municipal Corporation has proposed the following location for construction of the toilet complexes -

- i. Office campus of the Deputy Commissioner, Kamrup (M)
- ii. Mathgharia, Ward No. 24

16.2. Construction

a) The construction of the toilet will be as per the detailed design provided by Guwahati Municipal Corporation. The Detailed design and BOQ is provided in **annexure VI**

16.3. Minimum Technical Specifications for the Construction of Public Toilets

The Public Toilets shall be of modern attractive shape. The foundations shall be as per site requirement. The foundation shall be refilled with the excavated earth and shall be filled with gravel with due consolidation and compaction in layers. The walls shall be of brick masonry in super structure. The flooring for toilets shall be not less than 8 mm thick matt finished Ceramic tiles. Adequate measures to be taken to ensure that the slope for the access to the toilet for differently abled people and senior citizens is non-slippery. All norms and procedures shall confirm to the detailed specifications laid out in APWD norms. All specifications of items should be as per the bill of quantities as approved by GMC.

16.4. Sanitation and Water Supply

All the necessary sanitary fitting fixtures shall be use of standard specifications and the work shall be done through approved licensed plumber having a certificate to this effect. The fixtures should be leak proof. The water absorption of the ceramic surface shall be minimal to make it difficult for urine to remain in body and odor eliminated. All work, fittings and fixtures shall confirm to APWD norms, BIS standards and as per manufacturers specification and approved by GMC.

16.5. Electrical Fixtures

Providing 25mm dia PVC pipe for internal wiring and wiring with 1st class quality Finolex/ Fincab insulated copper wire with different gauges suitable for light points exhaust fans for air circulation, outside lighting and for advertisement boards with switches etc., complete for finished item of work with fittings. Separate Electric meter for electricity will be installed by Service Provider at their own cost and they will be liable to pay for the actual consumption of power. Connection shall be provided by the GMC from the nearest available electric point from where agency has to extend connection at his cost.

16.6. Standards of Maintenance of Public Toilets

a) The agency shall engage one person for every unit of Public Toilet for cleaning and washing the unit round the clock, including public holidays to carry out the following Sanitation works:

- Daily washing with water.
- Daily phenylwashing.
- Sweeping up to 5 mtrs around the structure and sprinkling of disinfectant mixture of 200 gms (50 gms bleaching powder and 150 gms lime).
- 0.5 liters of acid per unit.
- Removal of solid waste.
- Custodian duty (protecting the structure against damage and misuse) and to prevent open urination surrounding the unit.
- Removal of handbills and washing of scrubbing inside and outside the structure.

b) The agency shall have to furnish weekly report on the prescribed performance to the Health Officer, GMC through the area Sanitary Inspector/ Supervisor.

c) The agency or his representative shall personally visit the Public toilets regularly twice a day to keep watch over the performance of the workers employed by him.

d) The agency shall carry out the work by engaging men and equipments and provide the disinfectants and implements for cleaning and arrange for sufficient water supply at the urinal / toilets for Cleaning.

e) The agency should arrange for sufficient water supply at the structure for cleaning and washing.

f) The following implements / disinfectants shall be supplied by the Agency to the staff Engaged by them.

- Cleaning Brooms
- Sweeping brooms
- Coir brush
- Scraping Sheet
- Bamboo Basket
- Plastic containers
- Bamboo Reapers
- Plastic Buckets
- Plastic Mug
- Sponge piece
- Washing Soap
- Identity Card
- Apron inscribed“GUWAHATI MUNICIPAL CORPORATION”
- Phenyle
- Acid
- Bleaching powder and lime powder
- Any other commodity required for the proper functioning and maintenance of the complex

g) The officials authorized by the Commissioner of GMC will supervise the work from time to time and point out any unsatisfactory service rendered by the selected agency and shall be

entitled to give suggestions as may be considered necessary and the selected agency shall be bound to carry out the work.

h) In the event of incomplete and unsatisfactory service, negligence or slackness is found by the agency in carrying out the work, GMC shall call for the explanation and terminate the contract, if there is no improvement even after (repeated) instructions.

i) The selected agency shall ensure that the labour engaged by him to carry out the work shall not claim any right whatsoever against GMC by virtue of service rendered under this contract and shall not hamper the work by resorting to demonstration, agitation etc.

j) The selected agency shall be held responsible for all or any of the act done by the staff /workers and shall be alone responsible for the payment of wages or any loss or damage caused by them during the course of service or work undertaken and shall also be responsible and be liable for payment of any compensation under workmen compensation Act. GMC will not be liable for any such event whatsoever.

k) That agency shall not engage child labour and shall agree and permit the workers to avail weekly off.

l) The agency should make available Suggestion Box and Complaint Register within the premises of the Public Toilets for users.

m) The agency shall not sublease or assign any part or portion of the work or the whole on the basis of the commission to others. If such conduct or action is found and brought to the notice of GMC, GMC is entitled to rescind and cancel the contract altogether.

n) GMC has the authority either to suspend or to cancel the contract when it is not desirable to continue the contract at any point of time without giving any notice.

o) GMC also reserves the right to alter, modify, change or remove any of the conditions mentioned in the agreement without any reason.

16.7. Penalties for Lapses / Shortfalls

The penalty amounts will be levied to the agency if the maintenance is not done satisfactorily on any particular day or on receipt of any specific complaint to the effect that the cleaning is unsatisfactorily and also for not following the conditions laid down as follows:

Sl no	Performance Indicator	Penalty per item/all items/per day (Amount to be decided by the GMC)
1	Sweeping of the entire complex not done and sprinkling of disinfectants not done (once daily) and Cleaning and washing of the entire complex not attended (once daily)	Rs. 500.00/day
2	Cleaning and washing of toilets not attended (every hour)	Rs. 50.00 / hour
3	Supervisor absent (per day at each unit)	Rs. 500.00/day
4	Phenyle not used (per wash)	Rs. 100.00 / wash
5	Acid not used (weekly)	Rs. 500.00 / week
6	On genuine complaint from the user(s)	Rs. 1000.00 / complaint
7	On report from the inspection team/ visiting Officer	Rs. 1000.00

** The Penalty rate may be revised by the G.M.C. from time to time without any prior notice**

16.8. Conditions

- a) The agency shall carry out all the required work for construction of public toilet.
- b) The agency shall construct the public toilets within the timeframe of 6 months.
- c) The agency shall collect the user charges for any facilities (urinals/ toilets/bathing blocks) as per the decision of the GMC.
- d) GMC shall fix timing of the opening and closing of the Public Toilet.
- e) All operation and maintenance charge including washing cleaning, electricity charge, water charge will be borne by the Agency.
- f) The concession period for the project will be 10 years.
- g) The agency will be allowed to collect the user charge from the user and also the advertising revenue from the advertising space. However, the agency will have to bear all the necessary advertisement taxes as prescribed by the Guwahati Municipal Corporation.
- h) The detailed design of the toilet complex and the cost estimate will be as approved by Guwahati Municipal Corporation
- i) The agency shall construct the toilet complex as per the approved detailed architectural design prepared by Guwahati Municipal Corporation.
- j) Any modification in the design of the toilets during the construction, must be done after intimation to the GMC, and only after approval from the Chief Engineer, Guwahati Municipal Corporation
- k) The Guwahati Municipal Corporation shall provide land to the agency suitable to the requirement of toilet block in terms of size, location and workability etc. The title of the land will continue to vest with GMC.
- l) The agency shall collect the user charges from the users of Public toilets which is to be approved by the Guwahati Municipal Corporation. Any revision in charges shall be determined by the Guwahati Municipal Corporation in its sole discretion
- m) The agency shall operate and maintain the complexes to the entire satisfaction of Guwahati Municipal Corporation and clean regularly toilets, urinals, floors, walls, and ceilings of the interior as well as the exterior of the complexes and ensure continuous serviceability as also continuous availability of clean water. He shall ensure that the requisite quantity of cleaning materials such as phenyl, acid, naphthalene balls are used to ensure that the toilets look clean and free from foul smell at all time and that soap, tissue papers, hand driers are available to the extent required.
- n) The selected agency/ organization shall maintain the facility as per a maintenance schedule agreed between the two. The Guwahati Municipal Corporation may engage third party evaluators

to check the quality of maintenance and in case the maintenance is found to be deficient the Guwahati Municipal Corporation may fine the agency/ organization.

o) The charges towards electricity, water, sewage and other such amenities as required by the agency shall be included in the maintenance cost and will be borne by the agency.

p) The agency shall not display or allow to display or exhibit any picture / posture /statute or other articles in any part of the premises that are repugnant to the general standards of morality. The agency expressly agrees that the decision of the Guwahati Municipal Corporation in this regard shall be conclusive and binding on the agency.

q) There will be provision of advertisement spaces in each public toilet. The space for advertisement will be licensed to the agency for generating revenue.

r) The agency shall ensure that the premises are not used for playing games etc., which involves stakes / betting, play cards etc., or for any un-lawful activities.

s) Agency/ organization can use the premises for displaying any bill boards, advertisements, neon / glow signs etc after obtaining permission for the same from the Guwahati Municipal Corporation. The advertising policy for generating revenue will be regulated by the Guwahati Municipal Corporation concerned.

t) The agency shall construct structurally sound and aesthetically appealing facilities to the satisfaction of the Guwahati Municipal Corporation as per the plans prepared by the Guwahati Municipal Corporation. However, in areas where deviations are necessitated due to space or locational constraints, the Guwahati Municipal Corporation shall permit variation.

u) The agency shall ensure adequate water for general cleanliness of the public Toilets.

v) The agency shall ensure that construction of the public Toilets is completed within a period of 6 months from the date of handing over physical possession of each site. In case failure on the part of the agency to complete the work within the stipulated period is adjudged by the Guwahati Municipal Corporation to be attributable to causes within the control of the agency, then the agency shall pay to the Guwahati Municipal Corporation compensation (as assessed by Guwahati Municipal Corporation) subject to a maximum of 60 Days. The Guwahati Municipal Corporation may cancel the order if the work is not completed on or before 6 months from the date of Handing over the site. The decision of the Guwahati Municipal Corporation in this regard shall be final and binding upon the agency. Action under this clause of this agreement shall be without prejudice to any other right or remedy available under law to the Guwahati Municipal Corporation.

w) In case of loss due to theft or damage to the assets created in the public Toilets during the operation period (Concession period) , the agency shall be responsible for making good the same immediately at its own cost and shall continue to keep the complex operational and available for public use, to all times, as prescribed.

x) **Arbitration** : The procedure for arbitration will be as follows:

- a) In case of Dispute or differences arising between the GMC and agency resulting to any matter arising out of or connected with this agreement, such disputes or difference shall be settled in accordance with the Arbitration and Conciliation Act, 1996. The parties shall make efforts to agree on a sole arbitrator and only if such an attempt does not succeed and the Arbitral Tribunal consisting 3 arbitrator one each appointed by the GMC and agency and the third arbitrator to be chosen by the two Arbitrators so appointed by the parties to act as Presiding Arbitrator shall be considered. In case of failure of the two arbitrators appointed by the parties to reach upon a consensus within a period of 30 days from the appointment of the arbitrator appointed subsequently, the Presiding Arbitrator shall be appointed jointly by the GMC and agency.
- b) Arbitration proceedings shall be held in Guwahati, and the language of the Arbitration proceedings and that of all documents and communications between the parties shall be in English.
- c) The decision of majority of arbitrators shall be final and binding upon both parties. The cost and expenses of Arbitration proceedings will be paid as determined by the arbitral tribunal. However, the expenses incurred by each party in connection with the preparation, presentation etc. of its proceedings as also the fees expenses paid to the arbitrator appointed by such party or on its behalf shall be borne by its party itself.
- d) Performance under the contract shall continue during the arbitration proceedings and payments due to the agency by the GMC shall not be withheld, unless they are subject matter of the arbitration proceedings.
- e) The venue of arbitration proceeding shall be at Guwahati (Assam) only.

y) The Guwahati Municipal Corporation shall have the right to cancel / remove / terminate the agreement at any stage in case of breach of any of the stipulated terms and condition by the agency or in case their performance is not found satisfactory. The Guwahati Municipal Corporation shall be entitled to terminate the agreement in case of any neglect or lapse on the part of the agency in respect of the regular maintenance of the public Toilets in clean and hygienic conditions and to keep the public convenience in a state of good repairs at the cost of agency.

z) The site and the work assigned to the agency by the Guwahati Municipal Corporation shall not be transferred by the agency to any person, trust, society or institution in any manner whatsoever at any time whether during or after the termination of this agreement.

aa) The premises of public Toilets complex shall not be used by the agency for purpose other than that for which it is allowed under the agreement for operation and maintenance.

bb) The agency or its employees or agents shall behave and deal with courtesy with the users of these public Toilets.

cc) The agency shall ensure enforcement of existing labour laws. Minimum Wages Act and at no point of time, the Guwahati Municipal Corporation shall be drawn into litigations on these counts.

dd) The agency shall execute the agreement within 7 days on the receipt of issuance of letter of award.

ee) The agency shall ensure that services of water supply, sewerage, drainage, electricity, telephone etc., in this vicinity encountered during the period of construction / running /maintenance of the toilet block are not damaged. In case these are required to be shifted, the same shall be done by the permission of the department.

ff) After completion of each facility, the agency shall provide 3 sets of completion plans including plans of various services provided therein e.g. electricity, water supply, sewerage, drainage etc., including covered area along with inventory of various fitting & fixtures.

gg) On the completion of the contract period, the agency shall hand over the vacant possession of the public Toilets so constructed along with fixtures and fittings, inventory, structures in good working condition to the Guwahati Municipal Corporation within 24 hours and will not put any resistance failing which the premises shall be evicted and the Guwahati Municipal Corporation shall assume the occupation without any notice whereupon the agency will have no claim.

hh) Any of the conditions mentioned above can be altered, modified, changed or removed by the appropriate authority as per the necessity without assigning any reason and the new conditions shall be binding on the part of the agency.

16.9. Schedule of Payment

The Guwahati Municipal Corporation shall make payments towards capital cost of construction work of the public toilets complex to the selected agency/ organization as per the following schedule:

Sl no	Deliverables Details	Percentage of payment
1	Completion of the construction work up to plinth Level to be certified by the Chief Engineer of the Guwahati Municipal Corporation.	30% * (estimated cost –agency contribution)
2	Completion of the construction work up to roof level be certified by the Chief Engineer of the Guwahati Municipal Corporation..	30% * (estimated cost –agency contribution)
3	Completion of the entire construction work in every respect including provision for electricity and 24/7 water supply; and O & M arrangements making the complex fully operational - subject to verification and issuance of completion certificate by the Chief Engineer of the Guwahati Municipal Corporation.	30% * (estimated cost –agency contribution)
4	On successful completion of 1st Year of O & M	3% * (estimated cost –agency contribution)
5	On successful completion of 2nd Year of O & M	3% * (estimated cost –agency contribution)
6	On successful completion of 3rd Year of O & M	4% * (estimated cost –agency contribution)

16.10. Minimum Reserve Price

The minimum reserve price in terms of participatory contribution towards the project cost for the construction and maintenance of public toilet in (Location) is as follows

Name of the Location:

1) Office campus of the Deputy Commissioner, Kamrup (M)

Project Cost: Rs 15,12,250.00

Minimum Reserve price : Rs. 6,04,900.00 (40% of total project cost)

2) Mathgharia

Project Cost : Rs 19,34,600.00

Minimum Reserve price : Rs. 7,73,840.00 (40% of total project cost)

TECHNICAL PROPOSAL (STANDARD FORMAT)

**COVER LETTER
(On the Letterhead of the Bidder)**

Place:

Date:

FROM:

[Name & Designation of Contact Person
(Service Provider Side)
with Complete Address of Communication]

TO:

[Name & Designation of Contact Person
(Client Side)
with Complete Address of Communication]

Subject: Construction & Maintenance of Modern Public Toilets

We, the undersigned, offer to provide the services for the above in accordance with your Request for Proposal dated We are hereby submitting our application which includes this Technical Proposal, and a Financial Proposal sealed under a separate envelope. Our proposal is valid for acceptance for 6 months and we confirm that this proposal will remain binding upon us and may be accepted by you at any time before this expiry date. If negotiations are held during the period of validity of the Proposal, we undertake to negotiate on the basis of the merit of our proposal. Our Proposal is binding upon us and subject to the modifications resulting from contract negotiations, if any. We have examined the information provided in your Request for Proposal (RFP) and offer to undertake the work described in accordance with requirements. This proposal is valid for acceptance for 6 months and we confirm that this proposal will remain binding upon us and may be accepted by you at any time before this expiry date.

We accept that any contract that may result will comprise the contract documents issued with the RFP and be based upon the documents submitted as part of our proposal; and placed by the (*agency/ organization's name*). The Proposal (Technical & Financial) has been arrived at independently and without consultation, communication, agreement or understanding (for the purpose of restricting competition) with any other party invited to tender for this contract. We understand the obligations in paragraph 1 of the "Instruction to Bidders" and confirm we have no declarations to make.

We agree to bear all costs incurred by us in connection with the preparation and submission of this proposal and to bear any further pre-contract costs. Certain information included in this proposal would if disclosed prejudice our commercial interests.

I confirm that I have the authority of (**Agency/ Organization**) to submit proposal and to clarify any details on its behalf. We understand you are not bound to accept any Proposal you receive.

We remain,

Yours sincerely,

(Signature)

Name & Designation of Authorized Signatory

Name of the Agency/ Organization:

Address:

Details of Bidder
(On the Letter Head of the Bidder)

Sl no	Item	Response
1	Name of Bidder	
2	Registered Office Address with Fax, Telephone No., e-mail id of Organization	
3	Type of the Agency	Society/NGO/Company/Firm/Trust etc
4	Date of registration and registration no	
5	Name of the contact person	
6	Contact Person's Address with Fax, Telephone No., e-mail id of Contact Person	
7	Contact person Mobile No	
8	Brief description of the Bidder's main lines of business (Attach annual Report if available)	
9	Experience in the field of construction, O & M of public amenities / facilities (Give details) <i>Please attach Work Orders, Work Completion Certificates/ Reports</i>	
10	Financial Capability (Net worth) <i>Pease attach Audited Balance Sheet of last 3 FYs</i>	
11	Strategy to mobilize resources to accomplish the job on time <i>Pease attach a brief strategy document</i>	
12	Plan for Operation & Maintenance of the Complex <i>Pease attach a detailed O & M Plan</i>	
13	Any Other Point	

Certificate:

We confirm that we have read the relevant docket and understood the Scheme for Construction and maintenance of Public Toilets, particularly our scope of work, and other terms and conditions. We convey our acceptance of the terms and conditions. The undersigned confirms that he/she has the necessary authority to submit this RFP on behalf of the applicant.

Date:

(Signature of authorized person)

Place:

(Full Name and Seal)

**Format for Anti-Collusion Certificate
Anti-Collusion Certificate₂**

We undertake that, in competing for (and, if the award is made to us, in executing) the above contract, we will strictly observe the laws against fraud and corruption in force in India namely “Prevention of Corruption Act 1988”.

We hereby certify and confirm that in the preparation and submission of our Proposal, we have not acted in concert or in collusion with any other Bidder or other person(s) and also not done any act, deed or thing which is or could be regarded as anti-competitive. We further confirm that we have not offered nor will offer any illegal gratification in cash or kind to any person or agency in connection with the instant Proposal.

Dated thisDay of, 2014.

.....

(Name of the Bidder)

.....

(Signature of the Authorised Person)

.....

(Name of the Authorised Person with Seal)

Proof of Eligibility

Sl no	Eligibility Criteria	Supporting Document	Marks Alloted
1	The Agency should be registered as an entity	Submit copy of the registration certificate	10
2	The Agency should have an average net worth of two times the estimated value during the last three Financial years	Submit audited Financial statement/CA certification for the last three year	30
3	The Agency should be operational for last five years	Submit copy of the registration certificate along with profile of work done of similar nature for the last five years	20
4	The Agency should have previous experience in management (construction & Maintenance) of public utility service	Submit copy of the contract/work order with any municipality or any service provider in support of experience in managing public utility services.	20
5	The Agency should have adequate man power for carrying out the activity	Submit list of manpower (senior management and field level) available in organisation to show ability to carry out similar nature of assignment	20

*** The Agency must get 50% marks to qualify**

.....

(Signature of the Authorised Person)

.....

(Name of the Authorised Person with Seal)

Financial Offer (In agency letterhead)**Location:****Date:**

To:
The Commissioner
Guwahati Municipal Corporation
Panbazar, Guwahati

Sub: Construction & Maintenance of Public Toilets.

Ref: Your Notification No. _____ dated _____

Sir/Madam,

Having gone through this RFP document and having fully understood the Scope of Work for the Service contract as set out by GMC in the RFP, we are pleased to inform that we would offer our financial offer for (Location) -----

Sl no	Item	Participatory Contribution in % of the project Cost
	Construction of modern public toilets including operation, management & maintenance of the toilet	

We have reviewed all the terms and conditions of the Request for Proposal including the Form of Agreement and would undertake to abide by all the terms and conditions contained therein. I / we hereby declare that there are, and shall be, no deviations from the stated terms in the RFP document.

Yours faithfully,

For and on behalf of (Name of Bidder)

Duly signed by the Authorised Signatory of the Bidder

(Name, Designation and Address of the Authorised Signatory)

Detailed Design and BOQ for public toilet in the office Campus of the office of Deputy Commissioner, Kamrup(M)

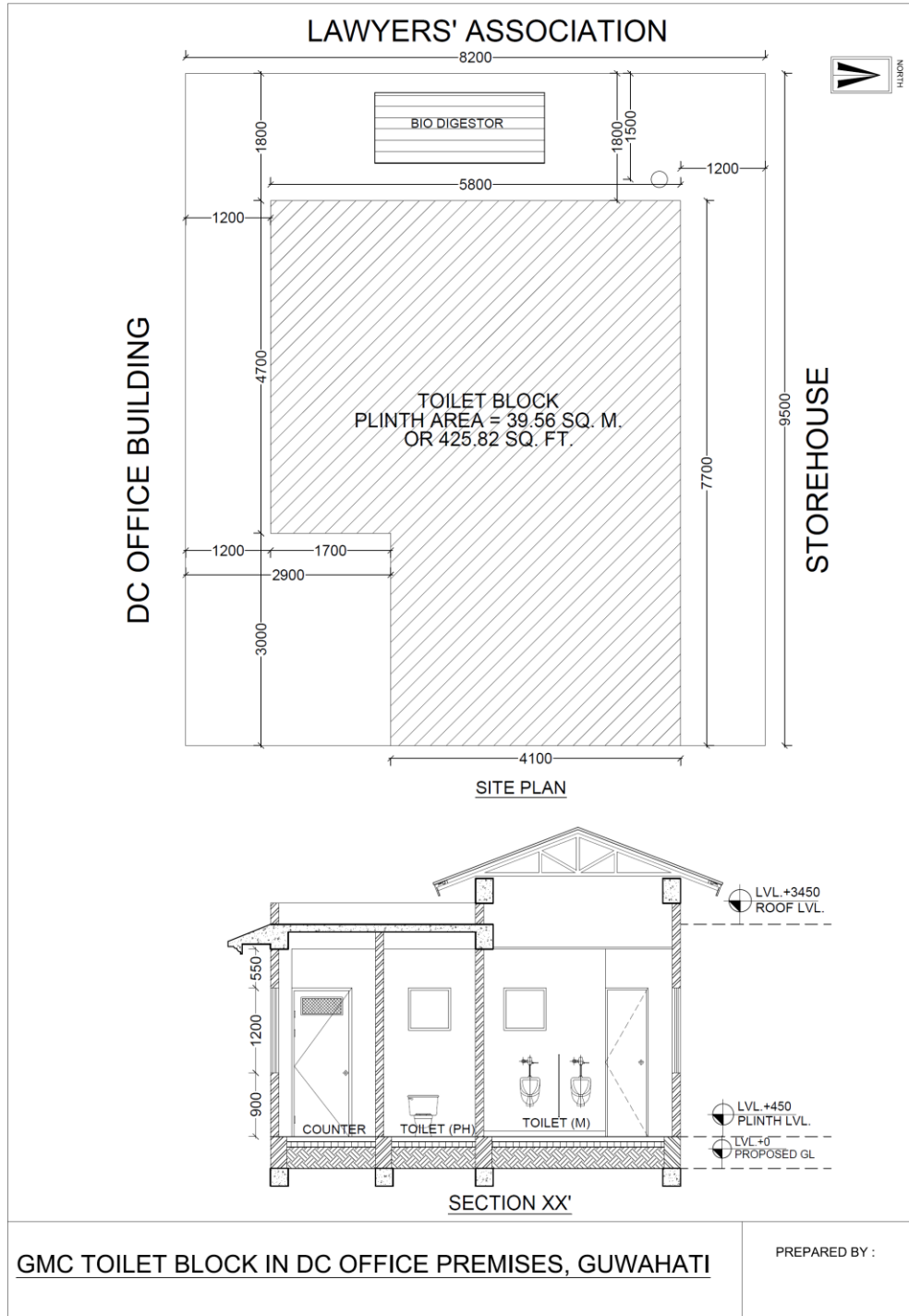

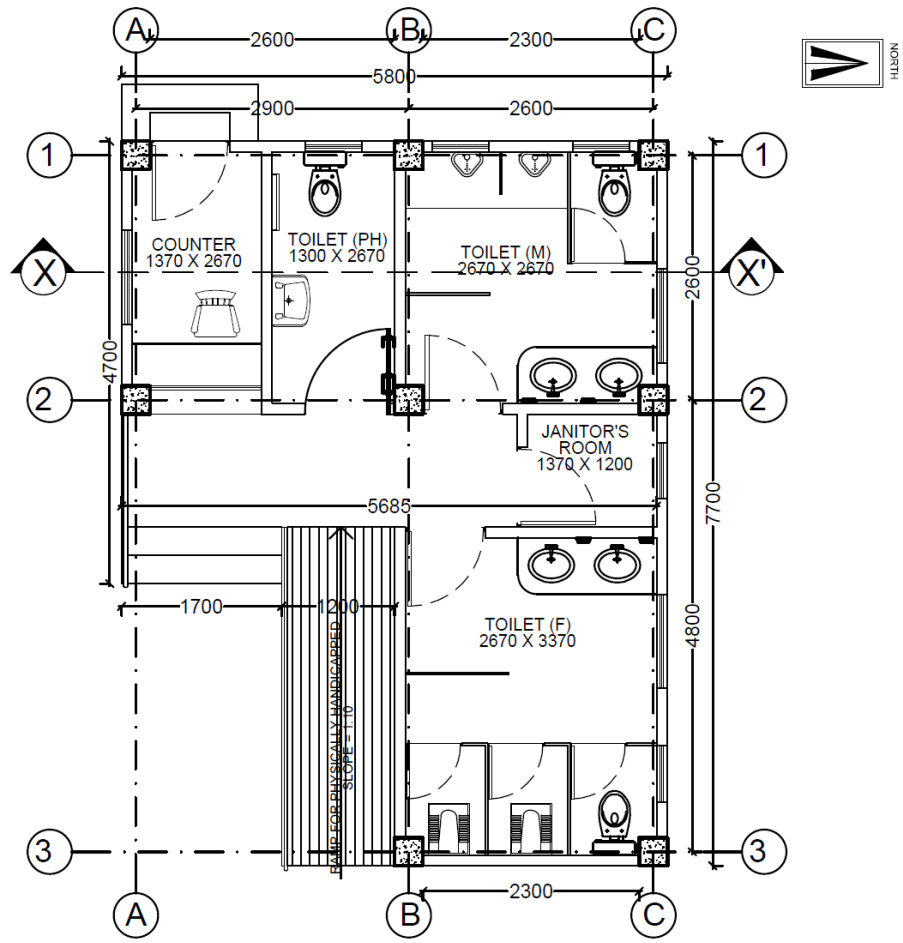

FLOOR PLAN



FRONT ELEVATION

GMC TOILET BLOCK IN DC OFFICE PREMISES, GUWAHATI

PREPARED BY :

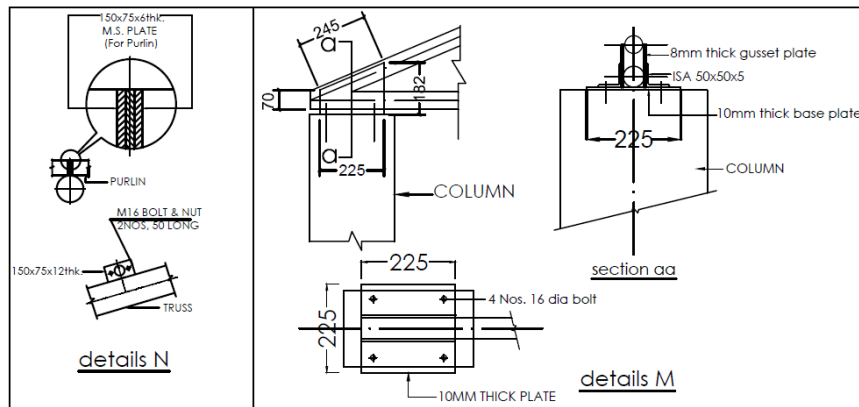
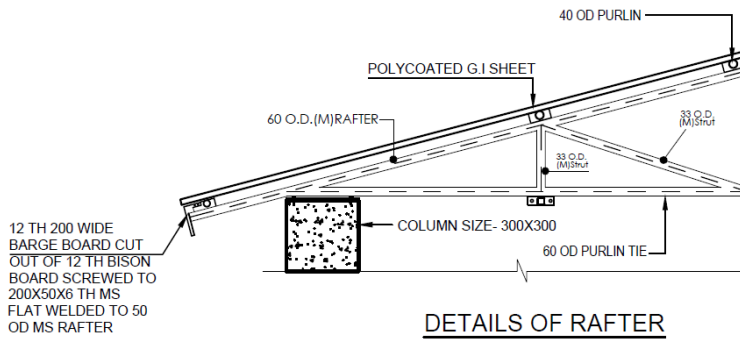
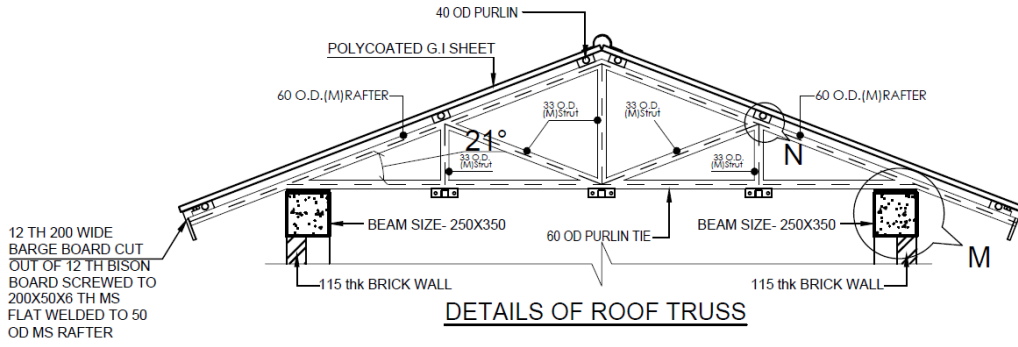

DETAILS - NTS
ROOF TRUSS DETAILS

**GMC TOILET BLOCK AT DC OFFICE
PREMISES, GUWAHATI**

PREPARED BY :

BEAM 250X350
WITH 3-16Ø BOTTOM,
2-12Ø TOP

300x300 column
with 4-12Ø

TIE BEAM 250X300
WITH 3-16Ø BOTTOM,
2-12Ø TOP

E.G.L.

2000MM
OR
AS/ SITE

FLAT BRICK
SOLING

75thk. 1:3:6
P.C.C.

75 mm thk. Flat Brick Soling
SECTION RR

CONFINING

CONFINING

600

600

250

450

1200

10 nos. 10Ø bothways

1200

TYPICAL ISOLATED FOOTING PLAN

GMC TOILET BLOCK AT DC OFFICE PREMISES, GUWAHATI

Total <i>Abstract</i> of Cost of construction of <i>TOILET BLOCK at DC Office Premises, Assam</i> based on 2013-14 Assam PWD Schedule of Rates.		
Sl. No.	Description	Amount in Rs.
1	Civil Works	9,29,054.59
2	Sanitary Works	1,30,045.00
3	Water supply Works	3,95,527.68
4	TOTAL(A)	14,54,627.27
5	Electrical Works @ 3% of TOTAL(A)	43,638.82
6	TOTAL (B)	14,98,266.09
7	Contingencies @ 1% of Total (B)	14,982.66
8	GRAND TOTAL	15,13,248.75
	GRAND TOTAL say	15,13,250.00

(Rupees Fifteen Lakhs Thirteen Thousand Two Hundred and Fifty only)

Estimated cost of construction of the proposed Toilet Block at *DC OFFICE Premises, GUWAHATI, ASSAM* based on Assam PWD Schedule of Rates for Civil Works 2013-14.

Item No.		Description of work	Unit	Qty.	Rate in Rupees	Amount in Rupees
BOQ	APWD					
1		EARTH WORK				
1.1	1.1(A)	(b) Earthwork in excavation for foundation trenches of walls, retaining walls, footings of column, steps, septic tank etc. including refilling (return filling) the quantity as necessary after completion of work, breaking clods in return filling, dressing, watering and ramming etc. and removal of surplus earth with all lead and lifts as directed and specified in the following classification of soils including bailing out water where necessary as directed and specified.	cum	45.74	138.12	6,317.71
1.2	1.3(c)	Earth / Sand filling with river sand or silt (predominantly non plastic) by truck carriage including loading and unloading in plinth in layer not more than 150 mm thick including necessary, carriage, watering, ramming etc. complete as directed and specified including payment of land compensation, Forest Royalty, Sales Tax and other duties and taxes as may be necessary.	cum	22.08	345.61	7,631.07
2		NOMINAL MIX. (P.C.C. WORKS)				
2.1	2.1.1	Plain cement concrete works with coarse aggregate of sizes 13mm to 32mm in foundation bed for footings, tie beams, steps, walls, brick works etc. as directed and specified including dewatering if necessary and curing complete (shuttering where necessary shall be measured and paid separately).				
	a)	(ii) In prop. 1 cement : 3 sand : 6 coarse aggregate by volume	cum	5.00	4,292.86	21,464.84
2.2	2.1.3	Providing and laying 25mm thick damp proof course with cement concrete in prop 1: 1.5: 3 with graded stone agg. Of 10mm down nominal size including providing approved damp proof admixture in proportion as recommended by the manufacturer including curing etc. complete as directed.	sqm	4.74	181.99	862.25
3		REINFORCED CEMENT CONCRETE WORKS				

3.1.1	2.2.1	Providing and laying controlled cement concrete of grade M 20 with 20mm down graded stone aggregate including dewatering if necessary, and curing complete, excluding cost of form work and reinforcement for reinforced concrete work (form work and reinforcement will be measured and paid separately).				
3.1.2	i)	(A) In substructure upto plinth level				
		(N)(b)Foundation, footings, columns with base, tie and plinth beam, grade beam, pile cap, base slab, retaining wall, walls of septic tank, inspection pit and the like and other works not below 100mm thick.	cum	8.18	6,063.65	49,590.80
3.1.3	ii)	(B) In super structure				
		Columns, pillars, posts, struts, suspended floor, roof, landing, shelf and support, balcony, lintel, sill band, beam, girder, bressumer, cantilever, staircase including preparing of top surfaces and furnishing and nosing.	cum	7.47	6,331.46	47,323.94
4		FORMWORK				
4.1	3.2.1	Providing form-work of 12mm thick Plywood Board so as to give a rough finish including centering, shuttering, strutting and propping etc. height of propping and centering below supporting floor to ceiling not exceeding 4.0 M. And removal of the same for in-situ reinforced concrete and plain concrete work in.				
4.1.1	3.2.1.1	Columns, pillars, posts, & struts of square/ rectangular/ polygonal in plan or any shape like Tee/L etc. having plane vertical face.	sqm	65.12	278.61	18,144.20
4.1.2	3.2.1.2	Sides and soffits of beam, beam haunchings, cantilever girders, bressumers, lintel and horizontal ties.				
		(a) For depth not exceeding 1.0M	sqm	44.06	231.00	10,178.32
4.1.3	3.2.1.3	Flat surfaces such as soffits of suspended floors, roofs, landings, cantilever slab, chajjas, balcony and the like				
		(a) Floors etc. upto 200 mm in thickness	sqm	30.19	345.67	10,435.78

4.1.4	3.2.3	Providing form-work of 12mm thick Plywood board and removal of the same in edges of slabs and breaks in floors and wall etc. of insitu reinforced concrete works upto first floor level.				
		(a) Thickness not exceeding 200 mm.	rm	36.84	171.87	6,331.69
5		BRICK WORK				
5.1	4.1.1	Providing brick flat soling in foundation and under floor with stone / best quality picked jhama bricks, sand packed and laid to level and in panel after preparing the subgrade as directed including all labour and materials, and if necessary dewatering, complete.	sqm	67.95	368.71	25,052.65
5.2	4.1.4(d)	Brick work in 1:6 cement mortar with 1st class brick including racking out joints and dewatering if necessary and curing complete as directed in sub-structure upto plinth level.	cum	6.43	5,515.11	35,471.33
5.3	4.1.8(A) (a)	112mm thick 1st class brick nogged wall in 1 cement : 4 sand mortar including racking out joints and curing complete as directed in super structure above plinth up to 1st floor (Protruding M.S. rod / Tor Steel of column to be embedded in cement mortar and will be measured and paid for separately).	sqm	87.11	653.01	56,880.60
6		FLOORING				
6.1	5.1.3	40 mm thick cement concrete floor consisting of 25 mm under layer of cement concrete in prop. 1:3:6 (1cement : 3 coarse sand : 6 coarse aggregate of 12.5 mm and down) and 15 mm thick wearing layer in cement concrete in prop. 1:1:2 (1cement :1 coarse sand : 2 coarse aggregate of size 10mm down) finished with a floating coat of neat cement finish using cement slurry for bond @ 2.75 kg. per square metre of floor area, wearing layer is to be laid in panels including curing etc. complete as directed.	sqm	10.05	405.53	4,075.58
6.2	5.7.1.2	Providing polished ceramic tiles of approved quality, size, shape and thickness not less than 8mm in dado on a bed of 10mm thick cement plaster 1 : 3 and jointed flush with white cement slurry mixed with matching pigment at all levels as specified and directed in toilet.				

		(a) Normal range Somany/Orient/Nitco/Asian make				
		(b) Of size 200mmx300mm and above	sqm	34.80	640.00	22,272.00
6.3	5.11.1	Providing anti-skid ceramic tiles of approved quality size, shape and thickness not less than 8mm on floors, skirtings over a cement mortar bed 15mm thick of 1:3 (1cement : 3 coarse sand) including cutting where necessary finished with flush pointing with Fix-A tiles (Choksey/ Sika/ Rouf/Pedelite) White Cement mixed with approved pigment to match shade of tiles complete at all levels as specified and directed.				
		(A)(i) Normal range (sizes 300mmx300m and above)	sqm	19.39	695.47	13,485.16
6.4	5.1.10	Cement plaster skirting with cement mortar in prop. 1:3 (1 cement : 3 coarse sand) finished with a floating coat of neat cement including rounding of junctions with floor.				
	a)	15mm thick	sqm	9.05	230.44	2,085.37
7		CEMENT PLASTERING				
7.1	6.2.3(b)	15 mm thick 1:4 cement plaster in single coat on fair side of brick/concrete walls for interior plastering up to 1st floor level including arises, internal rounded angles, chamfers and / or rounded angles not exceeding 80mm in girth and finished even and smooth including curing complete as directed.	sqm	105.30	217.46	22,898.54
7.2	6.2.2(b)	15 mm thick 1:4 cement plaster in single coat on rough side of brick/concrete walls for interior plastering up to 1st floor level including arises, internal rounded angles, chamfers and / or rounded angles not exceeding 80mm in girth and finished even and as specified and directed.	sqm	113.32	145.70	16,510.65
8		WOOD WORKS				
8.1	9.4.1	Providing barge board of size 200mm x 20mm with 1st class local Hollock/ Bonsum timber including fitting and fixing with necessary wood screws etc. complete.	R.m.	26.00	349.75	9,093.50

8.2	9.12.1	Providing and fixing flush door shutters solid core construction with frame of 1st class hard wood with cross band and face veneered ply wood face panels conforming to relevant I.S. code including oxidised iron butt hinges (100mm x 75mm x 3.5mm) 6 nos with necessary wood screws.				
	(b)	Non Decorative type face panel and block board core.				
	(ii)	35 mm thick	sqm	14.18	2,293.03	32,503.70
9		PAINTING				
9.1	13.2.2	c) Applying one coat of distemper primer of approved brand and manufacture on wall surface after thoroughly brushing the surfaces free from mortar droppings and other foreign matter and including preparing the surface even and sand papered smooth.	sqm	113.32	35.17	3,985.45
9.2	13.2.2	f) Distemping with dry distemper of approved brand and manufacture (two coats) and of required shade on new wall surface to give an even shade, over and including priming coat of white primer after thoroughly brushing the surface free from mortar droppings and other foreign matter and including preparing surface even and sand papered smooth.	sqm	113.32	78.37	8,880.85
9.3	13.9.3	Finishing old/ new wall with waterproofing weather coat smooth anti-fungal premium textured exterior painting of Sandtex Matt brand of Snowcem India Ltd. of required shade after cleaning and clearing the surface etc. including scaffolding complete as directed at all levels (two coats)	sqm	105.30	142.93	15,050.53
9.4	13.7.2(a)	Applying priming coat over new steel & other metal surface over 100mm in girth/ width after and including preparing the surface by thoroughly cleaning oil, grease, dirt and other foreign matter, sand papering and knotting.	sqm	44.55	33.96	1,512.92

9.5	13.7.4(i)(a)	Painting two coats surfaces over 100mm in width or grith (excluding priming coat) on new steel and other metal surface with enamel paint of approved brand and manufacture (Asian paint/Berger paint/ICI paint/J& N paint/Nerolac paint) to give an even shade including cleaning the surfaces of dirt, dust and other foreign matter sand papering and stopping.	sqm	44.55	61.95	2,759.87
10		GRILLS				
10.1	18.9.1	Providing & fixing Stainless Steel(Grade 304) railing made of Hollow tubes, channels, plates etc., including welding, grinding, buffing, polishing & making curvature(where required) & fitting the same with necessary stainless steel nuts & bolts complete, i.e. fixing the railing with necessary accessories & s.s. dash fasteners, s.s bolts etc of required size, on the top of the floor or the side of waist slab with suitable arrangement as per approval of Engineer in charge.	kg	14.47	582.31	8,424.40
11		DOOR FITTINGS				
11.1	15.2.1	Supplying, fitting, fixing anodized aluminium fittings of approved make, reasonably smooth, free from sharp edges and corners, flaws and other defects and with counter sunk holes for wood screws including necessary necessary screws etc. complete.				
11.2	(a)	Sliding door bolts				
	(ii)	250mm x 16mm sliding door bolt.	Each	5.00	260.27	1,301.35
11.3	(b)	Tower bolt				
11.3.1	(iv)	150mm x 10mm tower bolt.	Each	10.00	88.56	885.60
11.4	(c)	Door handles				
	(iii)	150 mm	Each	18.00	42.43	763.74
11.5	15.3.1(o)	Godrej mortice cylindrical lock	Each	5.00	1,323.44	6,617.20
12		ALUMINIUM DOORS, WINDOWS AND PARTITIONS				

12.1	11.1.1	Providing, fitting and fixing anodised aluminium windows and ventilators of standard sections of approved brand without horizontal glazing bars joints mitred and welded fitted with 6mm X 3.15 mm lugs 100 mm X 100 mm in 1:3:6 mix including providing and fixing handles, frictions stays, joining cleat, bolting device, locking arrangement, spring catch as required complete as specified and directed for all levels				
12.1.1	(a)	Side hung & top hung				
12.1.2		(ii) 5 mm frosted glass	sqm	1.80	6,020.77	10,837.39
12.2	11.1.2	Providing, fitting and fixing anodised aluminium sliding windows and ventilators of standard sections of approved brand without horizontal glazing bars, joints mitred and welded (manufactured to relevant IS specifications) and providing and fixing handles, angle cleat, rubber gasket, roller, bolting device, locking arrangements, screws etc as required complete as specified and directed for all levels.				
12.2.1	(a)	2 track sliding windows				
		(i) 5 mm frosted glass	sqm	3.60	4,302.54	15,489.14
12.3	11.4.1	Providing, fitting and fixing anodised aluminium partition walls of standard sections of approved brand, joints mitred and welded (manufactured to relevant I.S. specification) and providing and fitting angle cleat, rubber gasket, bolting device screws etc. at all levels.				
		(iv) Prelaminated Board	sqm	27.05	3,225.66	87,254.10
12.4	11.4.3	Providing, fitting and fixing anodised aluminium hollow section of approved brand (Indal section 9210) of size 63.50mm x 38.10mm x 2.5mm thick for aluminium frame partition wall, with a maximum spacing of frame 1.20m for horizontal/vertical member including aluminium cleat 32mm x 50mm x 4mm thick and fixing of pre-laminated board/ Nepal board/ Bhutan board with tapper cleat 20mm x 15mm x 1.2mm thick as directed by the department at all levels.				
		(iv) Prelaminated Board	Sqm	13.89	3,685.73	51,194.79
13	ANTI TERMITE TREATMENT					

13.1	26.1.1	Pre construction anti-termite treatment at the bottom of the foundation pits and walls on all sides upto a height of 300 mm from bottom of the excavation made for column, plinth beam, wall, trenches etc. by applying the emulsion @ 5 (five) litres per square meter of the surface area before starting construction work (supplying of necessary tools and accessories by the contractor) as per the direction of the Department complete.				
		(a) With aqueous emulsion having concentration 1:19 with chloropiropose solution (trichel or equivalent) and water. This provides emulsion containing 1% chloropiropose solution (by weight)	Sqm	18.00	77.09	1,387.62
13.2	26.1.2	Pre construction anti-termite treatment in back filling in immediate contact with the foundation structure after completion of column wall etc. to a depth of 450 mm and width 300 mm (when required refill in 200 mm thick layers) by applying the emulsion @ 5 (five) litres per square meter of the surface area before starting construction work (supplying of necessary tools and accessories by the contractor) as per the direction of the Department complete.				
		(a) With aqueous emulsion having concentration 1:19 with chloropiropose solution (trichel or equivalent) and water. This provides emulsion containing 1% chloropiropose solution (by weight)	Sqm	12.09	77.09	931.67
13.3	26.1.5	Pre construction anti-termite treatment by applying the soil along the external perimeter of the building after completion of construction to a distance close to the plinth wall as specified and as directed by the department upto a depth 300 mm making rod holes at 150 mm c/c upto 300 mm below by applying the emulsion @ 4.5 (four point five) litres per running meter ensuring moistening of the soil with the emulsion (supplying of necessary tools and accessories by the contractor) as per the direction of the Department complete.				

		(a) With aqueous emulsion having concentration 1:19 with chloropiophose solution (trichel or equivalent) and water. This provides emulsion containing 1% chloropiophose solution (by weight)	R.m	27.00	69.90	1,887.30
14		ROOF TRUSS				
14.1	18.3.1	Providing fitting, hoisting and fixing of roof trusses including purlins fabricated using MS circular hollow section conforming to relevant I.S. code, as per approved design and drawings including providing M.S. cleats, base plates, bolts and nuts and one coat of red oxide Zinc Chromate primer and two coats of approved enamel paints complete including fitting necessary cleats etc. for fixing ceiling joists as per design and drawing as directed.				
14.1.1		a) TATA make Circular Hollow section-CHS of Grade YST-310 conforming to I.S. Specification : 1161-1998	Qtl.	6.87	8,839.00	60,746.96
15		ROOFING				
15.1	8.1.26	Providing Pre Painted Galvanized Iron Sheet (PPGI) accessories (Ridges / Valley / Gutter /Flashing) at all levels including fitting and fixing self drilling, self tapping screws complete complete. TATA Blue scope/ Dyna roof / Durakolor /Wonder Roof or equivalent as directed by the Departement				
15.1.1		(iv) 0.60 mm thick	R.m.	16.99	588.66	9,998.39
15.2	8.1.33	Providing Pre Painted Galvanized Iron Sheet Roofing (PPGI) at all levels including fitting and fixing with self drilling, self tapping screws complete. (Roof trusses, purlins etc. to be measured and paid separately.) TATA Blue scope/ Dyna roof / Durakolor /Wonder Roof or equivalent as directed by the Departement				
15.2.1		(c) 0.60 mm thick	sqm	40.14	971.55	38,998.02
16		REINFORCEMENT				

16.1	18.1.1	Supplying, fitting and fixing in position TMT reinforcement bars conforming to relevant I.S. code for R.C.C. work / R.B. walling including straightening, cleaning, cutting and bending to proper shapes and length as per details, supplying and binding with 20G annealed black wire and placing in position with proper blocks, supports, chairs, spacers etc. complete (upto 1st floor level).				
	(a)	From Primary Producer				
	(ii)	Super ductile TMT reinforcement bars	Qtl	20.41	6,902.86	1,40,898.74
17		DOOR FRAMES				
17.1	18.7.1	Supplying, fitting and fixing door frame made of M.S. equal angle of size 40mm x40mmx5mm fabricated, welded, mitred and joined as per relevant I.S. Codes including fitting 8 nos. of M.S. hold fast, providing closing/ holding device for 2 nos. tower bolts of door for each side and 1 no. for fitting and fixing Aldrop (for single leaf) to the frame for fixing the door to the frame, applying primer to al steel surfaces fixing the frame to the wall/ R.C.C. members by embedding the hold fast securely in C.C. block of M-15 grade complete at all levels as specified and directed. (Door hinges to be paid as per relevant item of the schedule of rates).	R.m	44.55	354.60	15,797.43
18		WATERPROOFING				
18.1	22.1.1	Preparing the RCC surface in roof slab, chajjas, terraces, sunken slabs, septic tank, OH tank, raft slab, walls etc. by thoroughly cleaning with wire brush etc. followed by power washing for making the surface absolutely free from any foreign particles like dust, oil, grease etc. and allowing surface to dry complete as directed at all levels.	Sqm	20.11	26.78	538.55

18.2	22.3.1	<p>(A) Supplying, mixing, laying and applying the following waterproofing systems over Raft slabs, Roof slabs, Terraces etc. including curing complete as specified and directed by the Department at all levels.:</p> <p>(i) 1mm thick single coat of Master Crete M-81 of Choksey Chemicals /Dr. Sealkit Sealcrete (Asian Chemicals)/ mixed with cement in the ratio 1:2 as a prime coat.</p> <p>(ii) 3mm thick Polymer modified mortar - Cement sand mortar (in prop 1:3) mixed with Master Crete M-81/Dr. Sealkit Sealcrete (Asian Chemicals) @ 15% by weight of cement.</p> <p>(iii) 1mm thick coat of Master Crete M-81 /Dr. Sealkit Sealcrete (Asian Chemicals) mixed with cement in the ratio 1:2 as final coat.</p>	Sqm	20.11	1,208.50	24,302.94
GRAND TOTAL						9,29,054.59

Estimated cost of WATER SUPPLY WORKS for the proposed *TOILET BLOCK at DC Office Premises, ASSAM* based on Assam PWD Schedule of Rates for Sanitary & Water Supply Works 2013-14.

WATER SUPPLY WORKS

S.NO	SOR NO 13-14	DESCRIPTION	UNIT	QNTY	RATE	AMOUNT
1	3.1.6	Supplying fitting and fixing CPVC pipes having thermal stability for hot & cold water supply including all CPVC plain & brass threaded fitting including clamps at 1.0 M spacing. This include joining of pipes & fittings with one step CPVC solvent cement and testing of joints complete at all level as directed and specified.				
	(A)	In exposed surfaces or in trenches.				
	(e)	40 mm dia	R.m	18.50	308.16	5,701.58
1.1	(B)	Concealed by chiselling or breaking brick wall/C.C/RCC and making good the damages.				
	(a)	15 mm dia	R.m	10.00	167.44	1,674.40
	(b)	20 mm dia	R.m	20.00	191.93	3,838.60
	(c)	25 mm dia	R.m	25.00	247.02	6,175.50
2	3.2.1	Supplying fitting and fixing C.P bib cock 15 mm dia of approved brand directed and specified. (pipes will be measured separately)				
	II	Jaquare make				
	(a)	Continental/Clarion(ii) Bibcock long thread	Each	3	812.99	2,438.97
3	3.3.2	Supplying fitting and fixing C.P stop cock 15 mm dia of approved brand directed and specified. (pipes will be measured separately)				
	I	Jaquare make				
3.1	iv	15mm dia	Each	12	929.59	11,155.08
4	3.5.1	Supplying and fitting fixing C.P pillar cock of 15 mm dia of approved brand as specified and directed.				
	(II)	Jaquare make				
	(a)	Continental	Each	5	644.22	3,221.10
5	3.17.1	Supplying and fitting gun metal country pit valve (full way valve) ISI make as specified and directed.				
	(b)	40 mm dia	Each	5	1,858.02	9,290.10
6	5.4.2	Supplying and placing plastic cylindrical vertical claused top (PCVC) tank of Sintex / Polycon / Patton make over the staging with manhole cover with locking and cleaning arrangement including providing pads of size as required for inlet and outlet pipes				
	(III)	1000 litre capacity				
	(a)	Sintex make	Each	2	7,666.00	15,332.00

DEEP BORING						
7	5.3.4	Labour for boring hole for inserting tube well pipes through different soil/ rock media including hire charges of drill pipes, scaffolding, tools and plants as necessary and taking out the same and lowering pipes, fittings complete as directed by the Department.				
	(vi)	Borehole of 200mm diameter	Rm	85	560.90	47,676.50
8	5.3.5	Supplying, fitting and fixing pipes (plain/ bevel ended) for casing, conforming to relevant IS codes of practice including supplying and fitting of tubewell accessories, lowering of assembly pipes concentrically in the borehole followed by supplying and packing of pea gravel free from dirt, dust and other foreign materials in the annular space between the borehole and assembly pipes complete as directed.				
	(II)	PVC pipe SUPREME/PRINCE/FUSION/SFMC Brand				
	(viii)	200mm diameter	Rm	80	1,891.22	1,51,297.60
9	5.3.6	Supplying, fitting and fixing suction pipes (plain/ bevel ended) conforming to relevant IS codes of practice including supplying and fitting of accessories, lowering of assembly pipes concentrically in the casing pipes complete as directed .				
	(B)	PVC pipe SUPREME/PRINCE/FUSION/SFMC Brand				
	(viii)	160mm diameter	Rm	80	1,297.05	1,03,764.00
10	5.3.9	Supplying fitting and fixing ISI approved PVC filter 3.00 metre long.	Each	1	1,866.25	1,866.25
11	5.3.12	Development of the tubewell/ boring with compressor or by over pumping unit for 48 hours till sand free discharge is obtained.	job	1	14,500.00	14,500.00
12	5.3.13	Flushing, clearing, washing and watering of the tube well.	job	1	3,500.00	3,500.00
13	Electrical 39.3.2	1 HP single Phase Centrifugal monoblock pump set(Crompton Greaves/Aquatic/CRI/V-Guard/Calma make) with DOL Starter(Crompton Greaves/Control & Switch Gear/BCH/L & T/Siemens make)	Each	1	14,096.00	14,096.00
TOTAL WATER SUPPLY WORK						3,95,527.68

Estimated cost of SANITARY WORKS for the proposed *TOILET BLOCK* at *DC Office Premises, ASSAM* based on Assam PWD Schedule of Rates for Sanitary & Water Supply Works 2013-14.

SANITARY WORKS

S.NO	SOR NO 13-14	DESCRIPTION	UNIT	QNTTY	RATE	AMOUNT
2	1.2	Providing fitting and fixing vitreous china pedestal type water closet (European type W.C pan 400mm high) with seat and lead ,CP brass hinges and rubber buffers , CI/MS brackets , 40 mm dia flush band with fittings including painting of fittings and brackets, required. (Flushing Cistern to be paid separately)(A) Parryware make (a) White(v)Elite S Trap	nos	3	3,995.51	11,986.53
3	1.5	Supplying, fitting and fixing PVC flushing cistern with all internal fittings with CI brackets including fitting and fixing standard size CP flush pipe, union clamps etc. compete as directed and specified (pipes will be measred separately) (I) Parryware make (a) White (i) Economy Single Flush	nos	3	1,981.73	5,945.19
4	1.7	Providing fitting and fixing vitreous china flat back type lipped front urinal basin of with automatic flushing cistern with standard flush pipe and CP brass spreader andbrass unions, etc. complete including painting of fittings and brackets, cutting and making good the walls & floors wherever required. (A) Parryware make (a) White (ii) (ii) Integrated EFS-AC with power source (Cat No.C8097) / Integrated EFS- DC (Cat No.C8098)	nos	2	17,187.71	34,375.42
5	1.11	Supplying fitting and fixing vitreous china division plate including fitting and fixing compete as directed and specified. (i) Parryware Make (a) White (i) Partion Magnum / Large (Cat. No.C0571/07)	Each	1	1,817.26	1,817.26
6	1.9	Providing fitting and fixing vitreous china squatting plate urinal with automatic flushing cistern with standard flush pipe and CP brass spreader andbrass unions, etc. complete including painting of fittings and brackets, cutting and making good the walls & floors wherever required. (A) Parryware Make (i) White (Cat. No. C0503)	Each	2	3,156.68	6,313.36

7	1.13	Providing vitreous China wash basin with CI/MS brackets, C.P brass chain with plug,PVC waste pipe including painting of fittings and brackets, cutting and making good the walls wherever required. (Pillar cock, stop cocks, waste coupling are to be paid separately)				
7.1	1.13.2	Basin (without pedestal)				
7.1.1		(A) Parryware make(a)White				
7.1.1.1		(i) Star Basin 550 x 400 (Cat. No.C0450)	Each	5	2,256.68	11,283.40
8	1.21	Providing, fitting and fixing soap dish of Parryware make complete as specified and directed. (A) Parryware make				
	(ii)	Wall Soap tray (Cat. No.C9951)	Each	5	314.25	1,571.25
9	1.24	Supplying, fitting and fixing chrome plated C.P. towel rail of Sona make complete as specified and directed.				
	(c)	Parryware make(cat. No. C9948)	Each	5	1,150.65	5,753.25
10	1.27	Providing fitting and fixing robe hook of Jaquar make complete as directed and specified.				
	(i)	Continental (Cat.No. ACN-1191N)	Each	5	447.58	2,237.90
11	1.31	(a)Supplying, fitting and fixing C.P. Toilet paper holder of Jaquar make complete as directed and specified.				
	(i)	Continental toilet paper holder(Cat no. CAN-1151N)	Each	5	780.93	3,904.65
12	1.33	Proving fitting and fixing C.P. bottle trap,Jaquar make for basin etc. complete as directed and specified.				
	(i)	(i) Bottle trap 32mm size with 250mm long wall connection pipe (Cat. No.ALD-769)	Each	5	1,356.72	6,783.60
13	1.19	Providing fitting and fixing Decorative Mirror complete as directed and specified.(A)Parryware make(a) 800mx600mm	Each	5	3,417.43	17,087.15
14	1.32	Providing, fitting and fixing Chrome Plated waste coupling complete as directed and specified.(a) Jaquar make(i) 32mm	Each	5	405.16	2,025.80
TOTAL-----A						1,11,084.76
15	1.37.1	Supplying , fitting and fixing PVC pipes of 6 kg/sqcm (Supreme/Prince) or ther ISI approved including joining, fitting and fixing with clamp etc. as necessary complete at all levels including below G.L. as directed and specified.				
	(a)	In exposed surface or in trenches				

	(ii)	110 mm dia	R.m	16.82	630.80	10,609.43
16	1.37.4	Supplying fitting and fixing 45 degree PVC bend of Supreme/Prince make including joinining, fitting and fixing etc. as necessary complete at all levels including below G.L as directed .				
	(a)	In exposed surface or in trenches				
	(ii)	110 mm dia	Each	5	192.38	961.90
17	1.37.5	Supplying fitting and fixing P.V.C plain single tee of Supreme/Prince make including joinining, fitting and fixing etc. as necessary complete at all levels including below G.L as directed .				
	(a)	In exposed surface or in trenches				
	(ii)	110 mm dia	Each	5	278.76	1,393.80
18	1.37.6	Supplying fitting and fixing P.V.C single tee with door of Supreme/Prince make including joinining, fitting and fixing etc. as necessary complete at all levels including below G.L as directed .				
	(a)	In exposed surface or in trenches				
	(ii)	110 mm dia	Each	5	354.66	1,773.30
19	1.37.13	Supplying fitting and fixing P.V.C coupler of Supreme/Prince make including joinining, fitting and fixing etc. as necessary complete at all levels including below G.L as directed .				
	(a)	In exposed surface or in trenches				
	(ii)	110 mm dia	Each	5	133.49	667.45
20	1.39	Providing fitting and fixing PVC cowel of ISI make complete as directed and specified.(ii) 110mm dia. PVC cowel of ISI make	Each	3	153.12	459.36
21	1.42	Providing, fitting and fixing CP grating to the floor complete as directed.				
	(ii)	110mm dia	Each	12	257.82	3,093.84
					TOTAL-----B	18,959.08
					GRAND TOTAL-----A+B	1,30,043.84

Detailed Design and BOQ for public toilet at Mathgharia

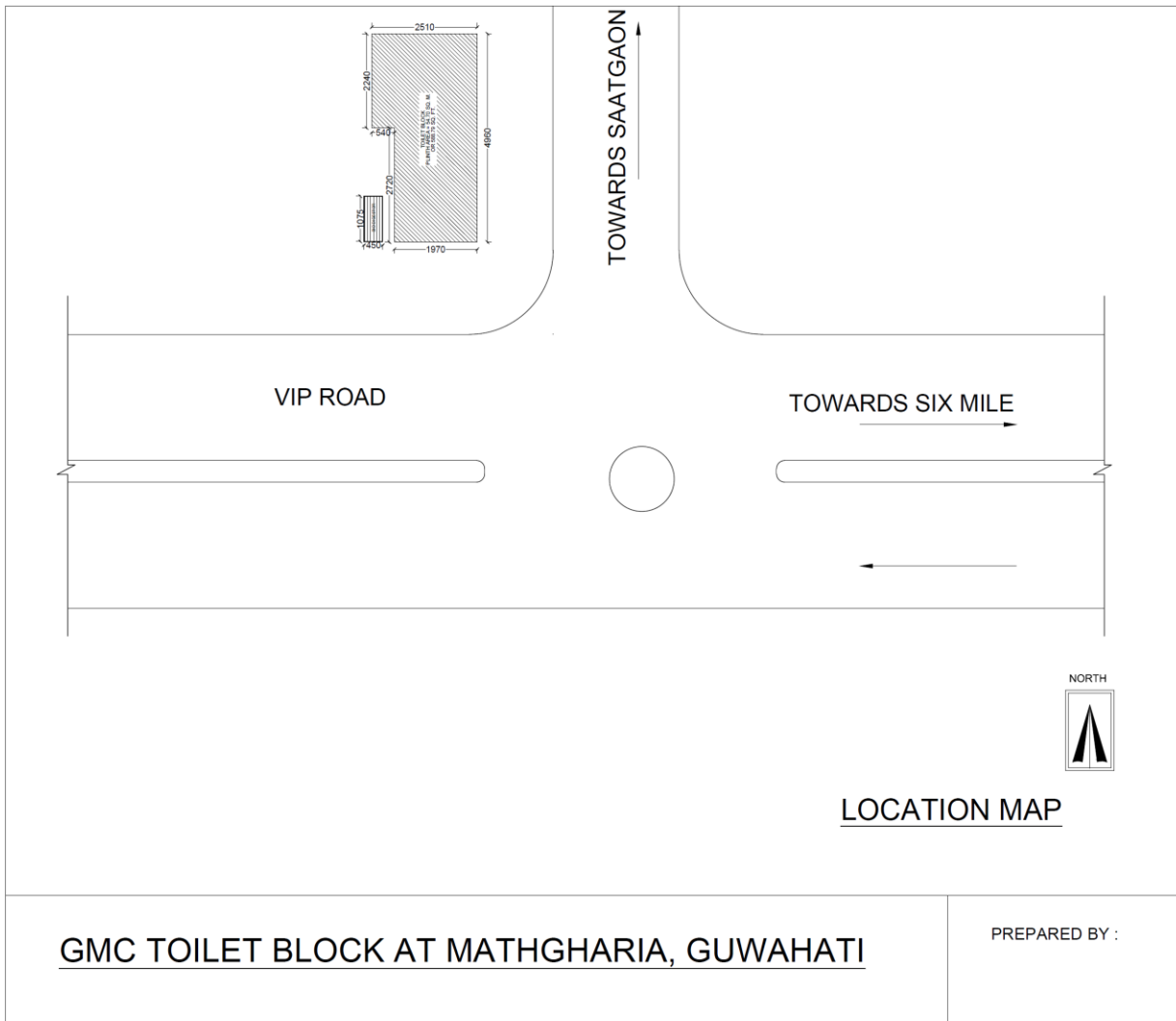

GMC TOILET BLOCK AT MATHGHARIA, GUWAHATI

PREPARED BY :

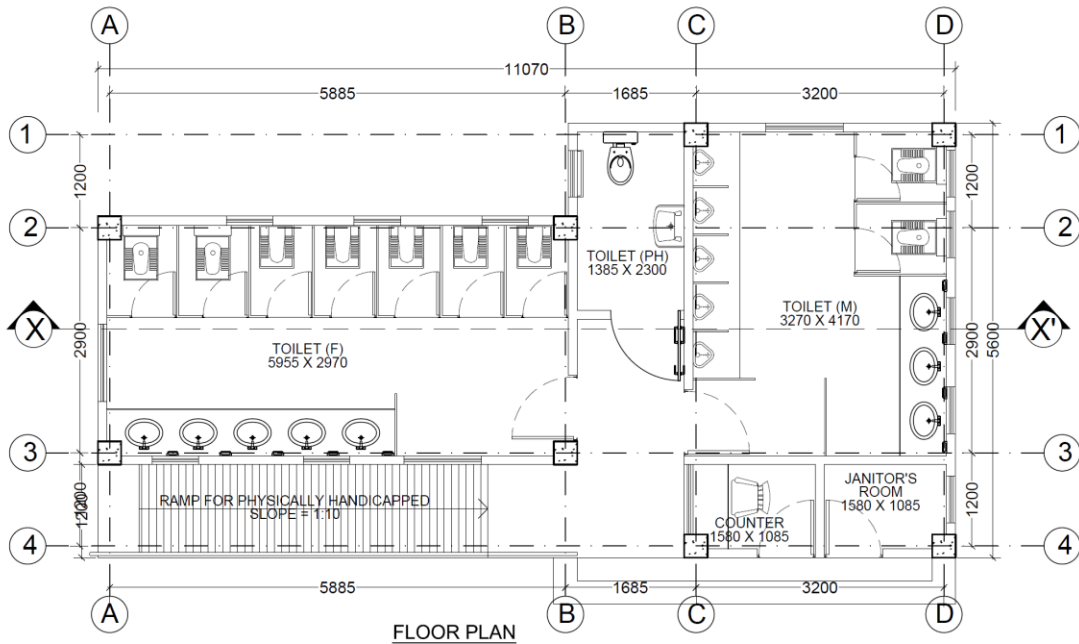

FLOOR PLAN

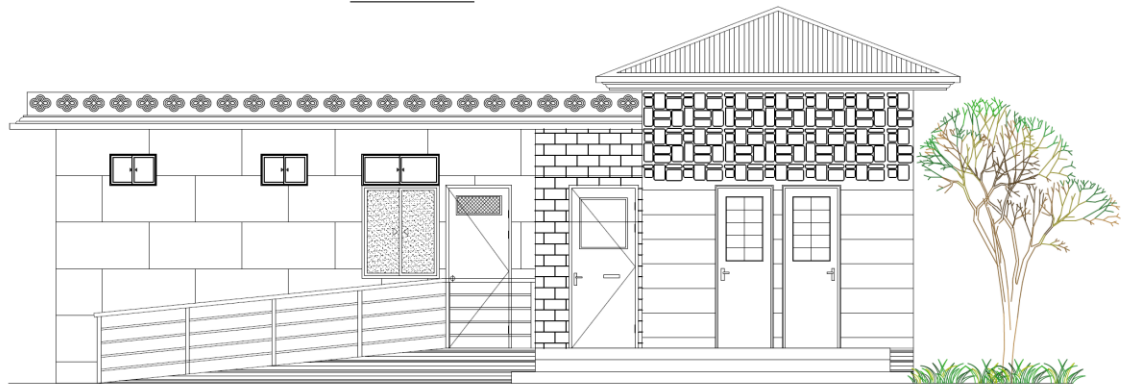

FRONT ELEVATION

GMC TOILET BLOCK AT MATHGHARIA, GUWAHATI

PREPARED BY :

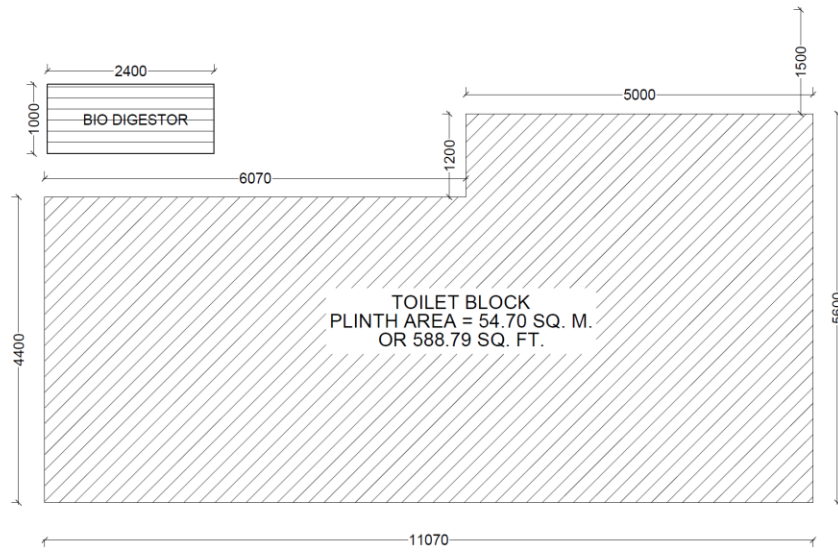

SITE PLAN

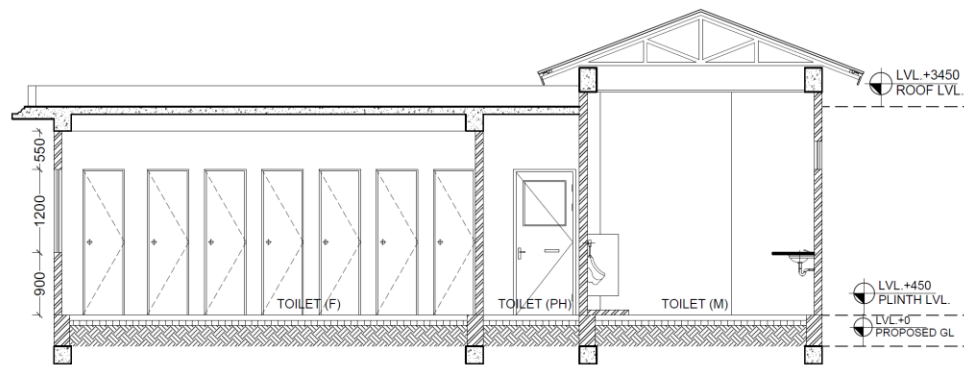

SECTION XX'

GMC TOILET BLOCK AT MATHGHARIA, GUWAHATI

PREPARED BY :

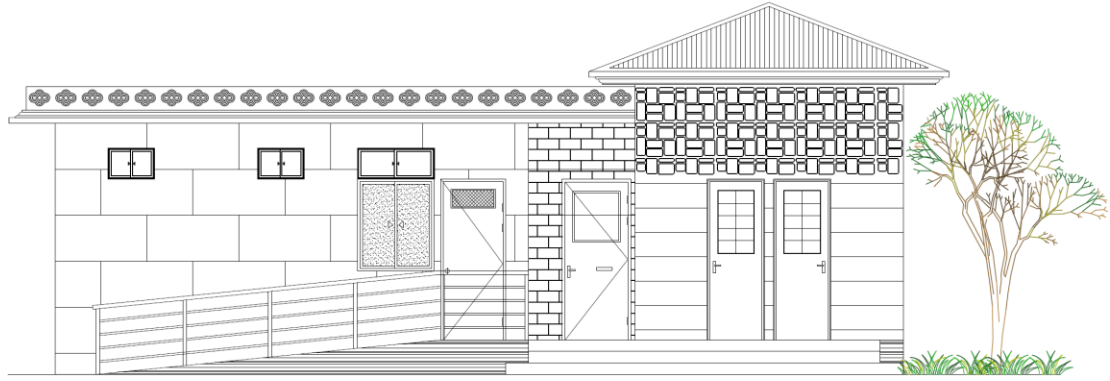
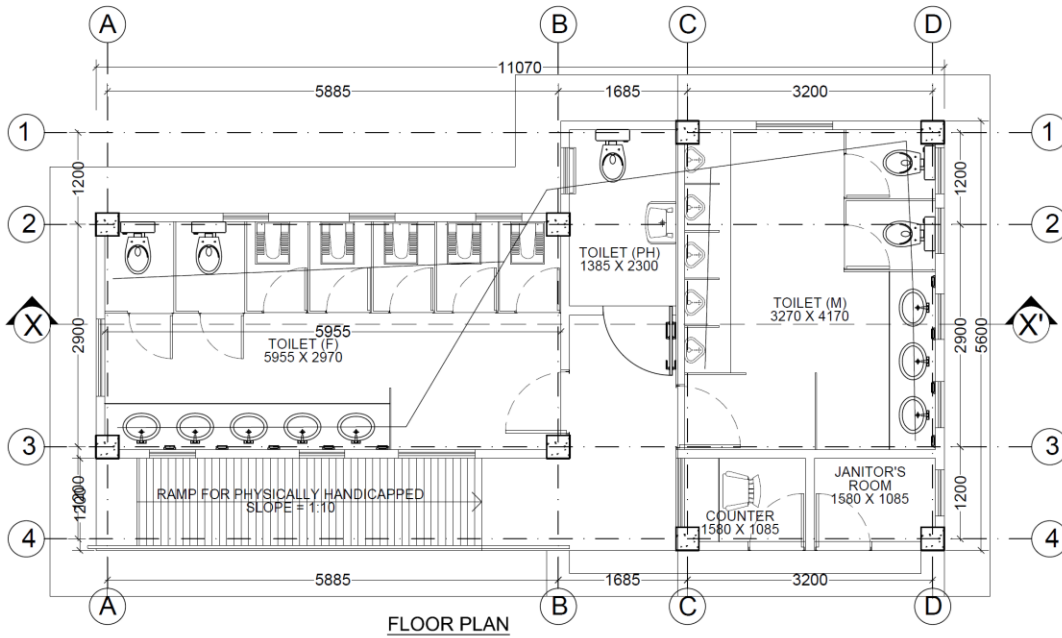

GMC TOILET BLOCK AT MATHGHARIA, GUWAHATI

PREPARED BY :

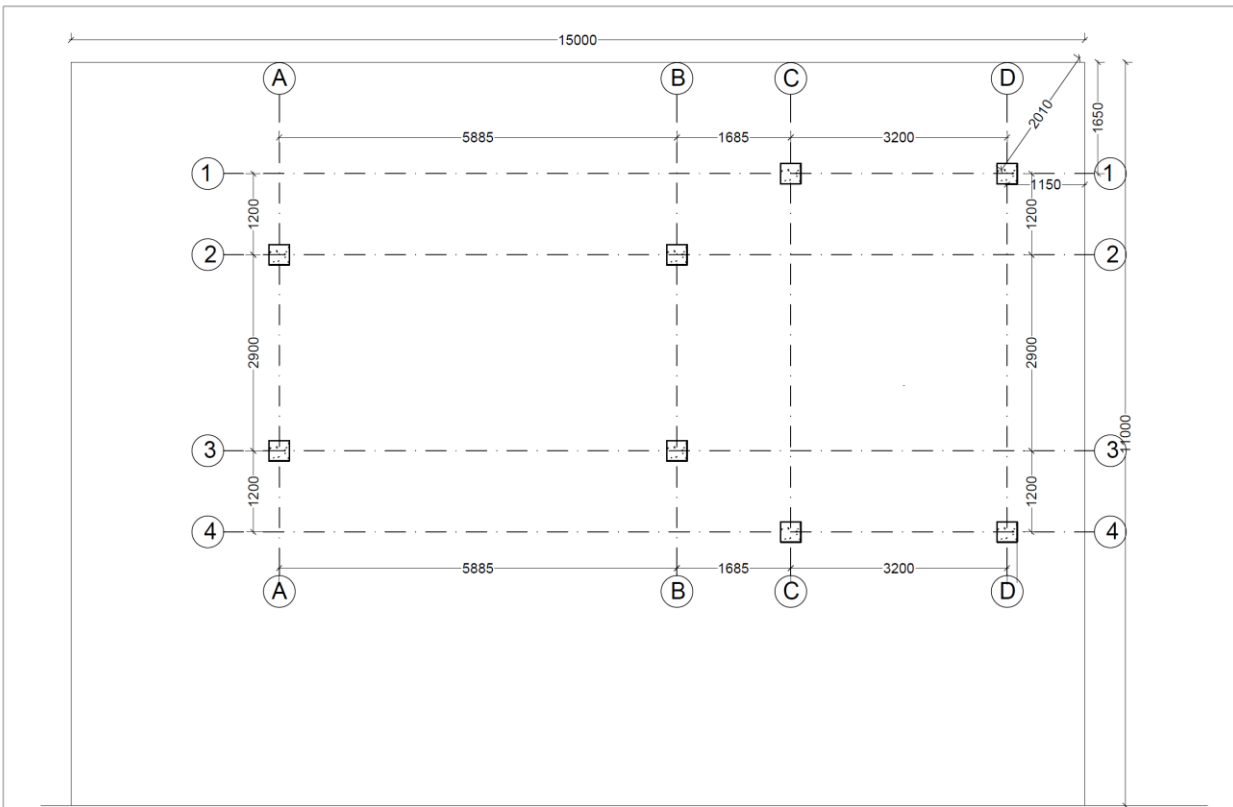

PLAN

LAYOUT PLAN

GMC TOILET BLOCK AT MATHGHARIA, GUWAHATI

PREPARED BY :

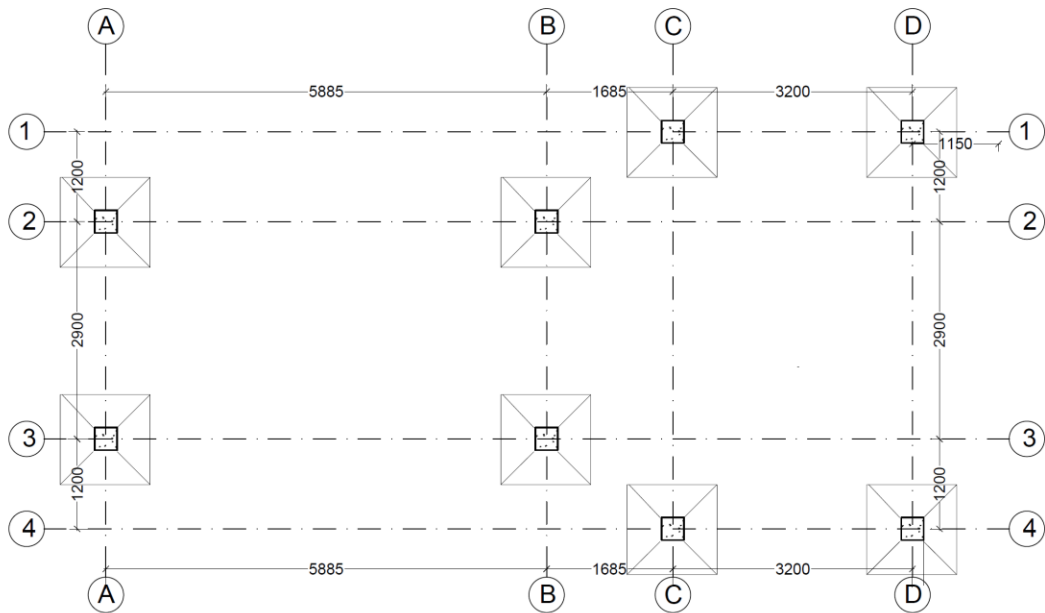

SCHEDULE OF FOOTING:

Footing. No.	Footing size	Footing reinforcement		Depth	
		long bars	short bars	d	D
F1	1200X1200	10 nos. #10	10 nos. #10	250	450

SCHEDULE OF COLUMN:

COLUMN SIZE	COLUMN REINFORCEMENT	STIRRUPS	
		CONFINING	BALANCE
300x300	4-#12	#8 @ 100c/c	#8 @ 200c/c

FOOTING LAYOUT PLAN & DETAILS

GMC TOILET BLOCK AT MATHGHARIA, GUWAHATI

PREPARED BY :

BEAM 250X350
WITH 3-16Ø BOTTOM,
2-12Ø TOP

300x300 column
with 4-12Ø

TIE BEAM 250X300
WITH 3-16Ø BOTTOM,
2-12Ø TOP

E.G.L.

2000MM
OR
AS/ SITE

BALANCE 600
600

CONFINING
CONFINING

FLAT BRICK
SOLING

250
450

75thk. 1:3:6
P.C.C.
75 mm thk. Flat Brick Soling
SECTION RR

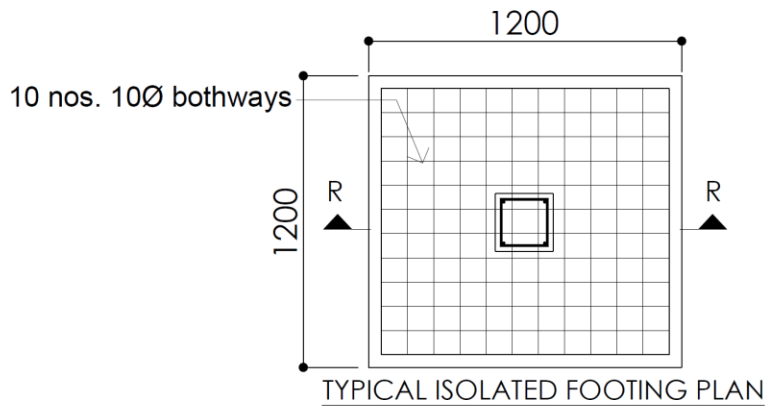

GMC TOILET BLOCK AT MATHGHARIA, GUWAHATI

PREPARED BY :

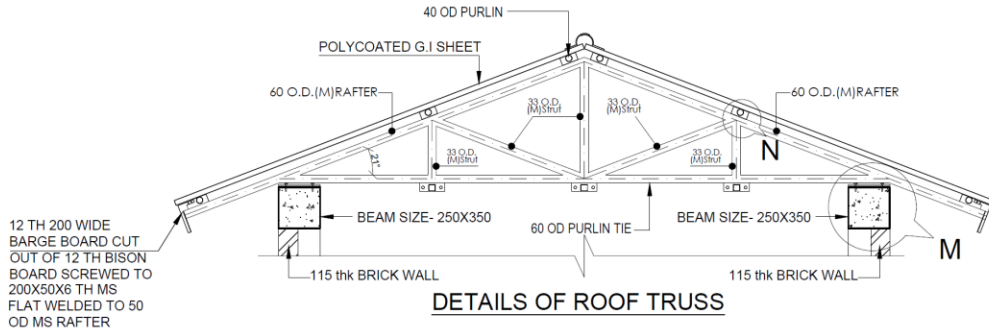

DETAILS OF ROOF TRUSS

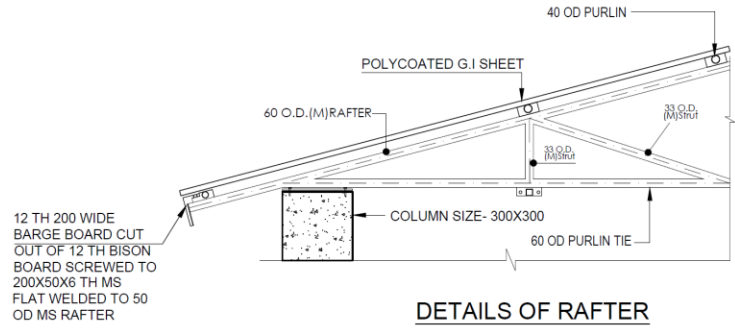

DETAILS OF RAFTER

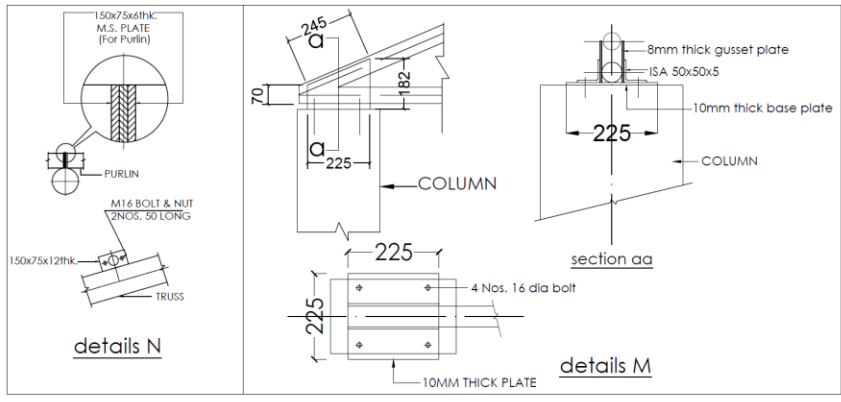

DETAILS - NTS
ROOF TRUSS DETAILS

**GMC TOILET BLOCK AT MATHGHARIA,
GUWAHATI**

prepared by

Total <i>Abstract</i> of Cost of construction of <i>TOILET BLOCK at Khanapara, Assam</i> based on 2013-14 Assam PWD Schedule of Rates.		
Sl. No.	Description	Amount in Rs.
1	Civil Works	11,83,711.97
2	Sanitary Works	2,37,612.69
3	Water supply Works	4,38,318.79
4	TOTAL(A)	18,59,643.45
5	Electrical Works @ 3% of TOTAL(A)	55,789.30
6	TOTAL(B)	19,15,432.75
7	Contingency @ 1% of TOTAL(B)	19,154.33
8	TOTAL	19,34,587.08
9	GRAND TOTAL say	19,34,600.00

(Rupees Nineteen lakhs thirty four thousand six hundred only)

Estimated cost of construction of the proposed Toilet Block at MATHGHARIA, GUWAHATI, ASSAM based on Assam PWD Schedule of Rates for Civil Works 2013-14.						
Item No.		Description of work	Unit	Qty.	Rate in Rupees	Amount in Rupees
BOQ	APWD					
1		EARTH WORK				
1.1	1.1(A)	(b) Earthwork in excavation for foundation trenches of walls, retaining walls, footings of column, steps, septic tank etc. including refilling (return filling) the quantity as necessary after completion of work, breaking clods in return filling, dressing, watering and ramming etc. and removal of surplus earth with all lead and lifts as directed and specified in the following classification of soils including bailing out water where necessary as directed and specified.	cum	49.33	138.12	6,814.09
1.2	1.3(c)	Earth / Sand filling with river sand or silt (predominantly non plastic) by truck carriage including loading and unloading in plinth in layer not more than 150 mm thick including necessary, carriage, watering, ramming etc. complete as directed and specified including payment of land compensation, Forest Royalty, Sales Tax and other duties and taxes as may be necessary.	cum	37.27	345.61	12,880.02
2		NOMINAL MIX. (P.C.C. WORKS)				
2.1	2.1.1	Plain cement concrete works with coarse aggregate of sizes 13mm to 32mm in foundation bed for footings, tie beams, steps, walls, brick works etc. as directed and specified including dewatering if necessary and curing complete (shuttering where necessary shall be measured and paid separately).				
	a)	In prop. 1 cement : 3 sand : 6 coarse aggregate by volume	cum	8.02	4,292.86	34,450.09

2.2	2.1.3	Providing and laying 25mm thick damp proof course with cement concrete in prop 1: 1.5: 3 with graded stone agg. Of 10mm down nominal size including providing approved damp proof admixture in proportion as recommended by the manufacturer including curing etc. complete as directed.	sqm	5.85	181.99	1,065.49
3		REINFORCED CEMENT CONCRETE WORKS				
3.1.1	2.2.1	Providing and laying controlled cement concrete of grade M 20 with 20mm down graded stone aggregate including dewatering if necessary, and curing complete, excluding cost of form work and reinforcement for reinforced concrete work (form work and reinforcement will be measured and paid separately).				
3.1.2	I)	(A) In substructure upto plinth level				
		(N)(b) Foundation, footings, columns with base, tie and plinth beam, grade beam, pile cap, base slab, retaining wall, walls of septic tank, inspection pit and the like and other works not below 100mm thick.	cum	9.08	6,063.65	55,045.36
3.1.3	B)	In super structure				
	(ii)(N)(b)	Columns, pillars, posts, struts, suspended floor, roof, landing, shelf and support, balcony, lintel, sill band, beam, girder, bressumer, cantilever, staircase including preparing of top surfaces and furnishing and nosing.	cum	14.19	6,331.46	89,837.36
4		FORMWORK				
4.1	3.2.1	Providing form-work of 12mm thick Plywood Board so as to give a rough finish including centering, shuttering, strutting and propping etc. height of propping and centering below supporting floor to ceiling not exceeding 4.0 M. And removal of the same for in-situ reinforced concrete and plain concrete work in.				
4.1.1	3.2.1.1	Columns, pillars, posts, & struts of square/ rectangular/ polygonal in plan or any shape like Tee/L etc. having plane vertical face.	sqm	63.26	278.61	17,625.98
4.1.2	3.2.1.2	Sides and soffits of beam, beam haunchings, cantilever girders, bressumers, lintel and horizontal ties.				

		(a) For depth not exceeding 1.0M	sqm	74.61	231.00	17,233.91
4.1.3	3.2.1.3	Flat surfaces such as soffits of suspended floors, roofs, landings, cantilever slab, chajjas, balcony and the like				
		(a) Floors etc. upto 200 mm in thickness	sqm	123.06	345.67	42,538.15
4.1.4	3.2.3	Providing form-work of 12mm thick Plywood board and removal of the same in edges of slabs and breaks in floors and wall etc. of insitu reinforced concrete works upto first floor level.				
		(a) Thickness not exceeding 200 mm.	rm	75.47	171.87	12,970.17
5		BRICK WORK				
5.1	4.1.1	Providing brick flat soling in foundation and under floor with stone / best quality picked jhama bricks, sand packed and laid to level and in panel after preparing the subgrade as directed including all labour and materials, and if necessary dewatering, complete.	sqm	95.76	368.71	35,308.68
5.2	4.1.4(d)	Brick work in 1:6 cement mortar with 1st class brick including racking out joints and dewatering if necessary and curing complete as directed in sub-structure upto plinth level.	cum	8.92	5,515.11	49,194.64
5.3	4.1.8(A) (a)	112mm thick 1st class brick nogged wall in 1 cement : 4 sand mortar including racking out joints and curing complete as directed in super structure above plinth up to 1st floor (Protruding M.S. rod / Tor Steel of column to be embedded in cement mortar and will be measured and paid for separately	sqm	88.88	653.01	58,041.16
6		FLOORING				

6.1	5.1.3	40 mm thick cement concrete floor consisting of 25 mm under layer of cement concrete in prop. 1:3:6 (1cement : 3 coarse sand : 6 coarse aggregate of 12.5 mm and down) and 15 mm thick wearing layer in cement concrete in prop. 1:1:2 (1cement : 1 coarse sand : 2 coarse aggregate of size 10mm down) finished with a floating coat of neat cement finish using cement slurry for bond @ 2.75 kg. per square metre of floor area, wearing layer is to be laid in panels including curing etc. complete as directed.	sqm	6.20	405.53	2,514.29
6.2	5.7.1.2	Providing polished ceramic tiles of approved quality, size, shape and thickness not less than 8mm in dado on a bed of 10mm thick cement plaster 1 : 3 and jointed flush with white cement slurry mixed with matching pigment at all levels as specified and directed in toilet.				
		(a) Normal range Somany/Orient/Nitco/Asian make				
		(b) Of size 200mmx300mm and above	sqm	44.88	640.00	28,723.20
6.4	5.11.1	Providing anti-skid ceramic tiles of approved quality size, shape and thickness not less than 8mm on floors, skirtings over a cement mortar bed 15mm thick of 1:3 (1cement : 3 coarse sand) including cutting where necessary finished with flush pointing with Fix-A tiles (Choksey/ Sika/ Rouf/Pedelite) White Cement mixed with approved pigment to match shade of tiles complete at all levels as specified and directed.				
		(A)(i) Normal range (sizes 300mmx300m and above)	sqm	40.21	695.47	27,964.85
6.5	5.1.10	Cement plaster skirting with cement mortar in prop. 1:3 (1 cement : 3 coarse sand) finished with a floating coat of neat cement including rounding of junctions with floor.				
	a)	15mm thick	sqm	21.78	230.44	5,017.95

6.6	5.7.3.4	Providing SUN ROCK HIGH CTS/ DEVI paver block/ tiles of concrete grade M30 or above of approved quality, size, shape of specified thickness over a base course of WBM or PCC including cutting where necessary finished with spreading, sweeping jointing sand and compacting the pavers using vibrating compactor as specified and directed.				
	d)	40mm thick	sqm	5.42	848.96	4,604.76
6.7	5.10.5	Providing polished granite slab of approved quality, size, shape and thickness not less than 18 mm on floors, skirtings, treads and risers of steps over cement mortar bed 15 mm thick in prop. 1:3 (1 cement : 3 coarse sand) including cutting where necessary finished with flush pointing with Fix-A-Tile Choksey/Sika/Pedelite/Rouf) /white cement slurry mixed with approved pigment to match the shade of granite slab, complete at all levels as specified and directed. (Cement plastering to be measured and paid separately). (Coloured pigment should be in conformity with colour of slab and as approved and directed by the Department).				
	iii)	Delux Quality				
	ii)	With White cement	sqm	3.62	3,332.89	12,068.39
7		CEMENT PLASTERING				
7.1	6.2.2(A)(b)	15 mm thick Cement plaster in single coat on rough side single or half brick wall for interior plastering up to 1st floor level including arises, internal rounded angles, not exceeding 80mm girth and finished even and smooth including curing complete as directed.	sqm	290.99	147.23	42,842.55
7.2	6.2.2(B)(b)	15 mm thick Cement plaster in single coat on fair side single or half brick wall for interior plastering up to 1st floor level including arises, internal rounded angles, not exceeding 80mm girth and finished even and smooth including curing complete as directed.	sqm	80.15	145.70	11,678.13
8		PAINTING				

8.1	13.3.4	Providing two coats of Birla white wall care putty (Water Resistant White Cement based putty for concrete/ mortar walls and ceiling both internal and external) after removing all loosely adhering material from the wall surface with the help of emery stone, putty blade or wire brush and moistening the wall with sufficient quantity of clean water as specified and directed by the department. (Total thickness of two coats is maximum 1.5mm)	sqm	175.44	35.17	6,170.14
8.2	13.4.7	Wall Painting (two coats) with plastic emulsion paint approved brand and manufacture (Asian Paint/Berger paint/ ICI paint/J&N paint/Nerolac) on new surface to give an even shade after thoroughly brushing the surfaces free from mortar droppings and ther foreign matter and sand papered smooth. a) plastic emulsion paint of approved brand and manufacture (Asian Paint/Berger paint/ ICI paint/J&N paint/Nerolac)	sqm	175.44	76.99	13,506.93
8.3	13.9.3	Finishing old/ new wall with waterproofing weather coat smooth anti-fungal premium textured exterior painting of Sandtex Matt brand of Snowcem India Ltd. of required shade after cleaning and clearing the surface etc. including scaffolding complete as directed at all levels (two coats)	sqm	195.71	142.93	27,972.12
8.4	13.7.2(a)	Applying priming coat over new steel & other metal surface over 100mm in girth/ width after and including preparing the surface by thoroughly cleaning oil, grease, dirt and other foreign matter, sand papering and knotting.	sqm	11.21	33.96	380.52
8.5	13.7.4(i)(a)	Painting two coats surfaces over 100mm in width or grith (excluding priming coat) on new steel and other metal surface with enamel paint of approved brand and manufacture (Asian paint/Berger paint/ICI paint/J& N paint/Nerolac paint) to give an even shade including cleaning the surfaces of dirt, dust and other foreign matter sand papering and stopping.	sqm	11.21	61.95	694.15

9		GRILLS				
9.1	10.3	Supplying, fitting and fixing anodised aluminium decorated grill with anodised aluminium rectangular frame of 'F' and 'H' section fitted with walls, columns or stiffeners by special type of screws as per specification by the Department for all levels. (Aluminium Alloy procured from primary aluminium producer (On submission of certificate of alloy purchasing from primary producer)	Sqm	11.21	2,098.22	23,510.56
10		ALUMINIUM DOORS AND WINDOWS				
10.1	11.1.1	Providing, fitting and fixing anodised aluminium windows and ventilators of standard sections of approved brand without horizontal glazing bars joints mitred and welded fitted with 6mm X 3.15 mm lugs 100 mm X 100 mm in 1:3:6 mix including providing and fixing handles, frictions stays, joining cleat, bolting device, locking arrangement, spring catch as required complete as specified and directed for all levels				
10.1.1	(a)	Side hung & top hung				
10.1.2		(ii) 5 mm frosted glass	sqm	4.32	6,020.77	26,009.73
10.2	11.1.2	Providing, fitting and fixing anodised aluminium sliding windows and ventilators of standard sections of approved brand without horizontal glazing bars, joints mitred and welded (manufactured to relevant IS specifications) and providing and fixing handles, angle cleat, rubber gasket, roller, bolting device, locking arrangements, screws etc as required complete as specified and directed for all levels.				
10.2.1	(a)	2 track sliding windows				
		(i) 5 mm frosted glass	sqm	6.48	4,302.54	27,880.46

10.3	11.2.1	Providing, fitting and fixing anodised aluminium framed glazed doors with anodised aluminium frame made of 100 X 45 X2.5 mm section of approved brand with door style of size 88 X 45 X 2.5 mm, top rails 50 X 45 X 2 mm lock rails 100 X 45 X 2 mm and bottom rails 100 X 45 X 2.5 mm fitted with glazing clip, special type rubber gasket complete including hydraulic floor spring, pivot, tower bolt in each leaf, aluminium door handle, lock, angles, cleat etc complete as apesified and directed by the department at all levels				
	(ii)	5 mm frosted glass	sqm	5.67	10,461.07	59,314.27
	(iv)	Prelaminated Board	sqm	3.15	10,506.21	33,094.56
10.4	11.5.1	Providing, fitting and fixing anodised aluminium framed glazed doors with partition walls partly glass and partly prelaminated board with anodised aluminium frame made of 100mm x 43mm x 2mm sections of approved brand with doors style of size 81mm x 43mm x 2mm, top rails 46mm x 43mm x 2mm, lock rails 81mm x 43mm x 2mm, fitting with glazing clip, special rubber type gasket complete including hydraulic floor spring pivot aluminium door handle lock angles cleat etc. complete as directed by the department at all levels.				
	(v)	Prelaminated Board	sqm	9.50	3,668.19	34,856.33
11		ANTI TERMITE TREATMENT				
11.1	26.1.1	Pre construction anti-termite treatment at the bottom of the foundation pits and walls on all sides upto a height of 300 mm from bottom of the excavation made for column, plinth beam, wall, trenches etc. by applying the emulsion @ 5 (five) litres per square meter of the surface area before starting construction work (supplying of necessary tools and accessories by the contractor) as per the direction of the Department complete.				

		(a) With aqueous emulsion having concentration 1:19 with chloropirophose solution (trichel or equivalent) and water. This provides emulsion containing 1% chloropirophose solution (by weight)	Sqm	18.00	77.09	1,387.62
11.2	26.1.2	Pre construction anti-termite treatment in back filling in immediate contact with the foundation structure after completion of column wall etc. to a depth of 450 mm and width 300 mm (when required refill in 200 mm thick layers) by applying the emulsion @ 5 (five) litres per square meter of the surface area before starting construction work (supplying of necessary tools and accessories by the contractor) as per the direction of the Department complete.				
		(a) With aqueous emulsion having concentration 1:19 with chloropirophose solution (trichel or equivalent) and water. This provides emulsion containing 1% chloropirophose solution (by weight)	Sqm	15.51	77.09	1,195.90
11.3	26.1.5	Pre construction anti-termite treatment by applying the soil along the external perimeter of the building after completion of construction to a distance close to the plinth wall as specified and as directed by the department upto a depth 300 mm making rod holes at 150 mm c/c upto 300 mm below by applying the emulsion @ 4.5 (four point five) litres per running meter ensuring moistening of the soil with the emulsion (supplying of necessary tools and accessories by the contractor) as per the direction of the Department complete.				
		(a) With aqueous emulsion having concentration 1:19 with chloropirophose solution (trichel or equivalent) and water. This provides emulsion containing 1% chloropirophose solution (by weight)	R.m	33.34	69.90	2,330.47
12	REINFORCEMENT					

12.1	18.1.1	Supplying, fitting and fixing in position TMT reinforcement bars conforming to relevant I.S. code for R.C.C. work / R.B. walling including straightening, cleaning, cutting and bending to proper shapes and length as per details, supplying and binding with 20G annealed black wire and placing in position with proper blocks, supports, chairs, spacers etc. complete (upto 1st floor level).				
	(a)	From Primary Producer				
	(ii)	Super ductile TMT reinforcement bars	Qtl	26.18	6,902.86	1,80,684.76
13		WATERPROOFING				
13.1	22.1.1	Preparing the RCC surface in roof slab, chajjas, terraces, sunken slabs, septic tank, OH tank, raft slab, walls etc. by thoroughly cleaning with wire brush etc. followed by power washing for making the surface absolutely free from any foreign particles like dust, oil, grease etc. and allowing surface to dry complete as directed at all levels.	Sqm	48.39	26.78	1,295.88
13.2	22.3.1	(A) Supplying, mixing, laying and applying the following waterproofing systems over Raft slabs, Roof slabs, Terraces etc. including curing complete as specified and directed by the Department at all levels.: (i) 1mm thick single coat of Master Crete M-81 of Choksey Chemicals /Dr. Sealkit Sealcrete (Asian Chemicals)/ mixed with cement in the ratio 1:2 as a prime coat. (ii) 3mm thick Polymer modified mortar - Cement sand mortar (in prop 1:3) mixed with Master Crete M-81/Dr. Sealkit Sealcrete (Asian Chemicals) @ 15% by weight of cement. (iii) 1mm thick coat of Master Crete M-81 /Dr. Sealkit Sealcrete (Asian Chemicals) mixed with cement in the ratio 1:2 as final coat.	Sqm	48.39	1,208.50	58,479.32
14		ROOFING				

14.1	8.1.33	Providing Pre Painted Galvanized Iron Sheet Roofing (PPGI) at all levels including fitting and fixing with self drilling, self tapping screws complete. (Roof trusses, purlins etc. to be measured and paid separately.) TATA Blue scope/ Dyna roof / Wonder Roof or equivalent as directed by the Departement				
	(iii)	0.50 mm thick	Sqm	34.84	802.77	27,965.62
14.2	8.1.34	Providing Pre Painted Galvanized Iron Sheet (PPGI) accessories (Ridges / Valley / Gutter /Flashing) at all levels including fitting and fixing self drilling, self tapping screws complete complete.TATA Blue scope/ Dyna roof / Wonder Roof or equivalent as directed by the Departement				
	(iii)	0.50 mm thick	RM	12.75	398.81	5,084.83
14.3	9.4.1	Providing barge board of size 200mm x 20mm with 1st class local Hollock/ Bonsum timber including fitting and fixing with necessary wood screws etc. complete.	RM	23.00	349.75	8,044.25
14.4	7.5.1	Providing, fitting and fixing in position false ceiling of 6mm thick Bison panel (cement bonded particle board) on timber frame of 1st class local wood (Hollock/ Bonsum/ Sundi) of 50mm x 50mm spaced at not more than 1.20m apart , fixed to the wall at the end with necessary nails, wood screws, hooks,bolts etc. including painting (one coat primer and two coats of painting) as necessary complete as directed by the Department for all levels.				
	(a)	Both sides commercial	Sqm	31.96	786.20	25,126.95
15		ROOF TRUSS				

15.1	18.3.1	<p>Providing fitting, hoisting and fixing of roof trusses including purlins fabricated using MS circular hollow section conforming to relevant I.S. code, as per approved design and drawings including providing M.S. cleats, base plates, bolts and nuts and one coat of red oxide Zinc Chromate primer and two coats of approved enamel paints complete including fitting necessary cleats etc. for fixing ceiling joists as per design and drawing as directed.</p>				
	(b)	Using other ISI marked approved circular hollow section	Qtl	5.98	8,410.00	50,307.39
		GRAND TOTAL				11,83,711.97

Estimated cost of SANITARY WORKS for the proposed *TOILET BLOCK at MATHGHARIA, ASSAM* based on Assam PWD Schedule of Rates for Sanitary & Water Supply Works 2013-14.

SANITARY WORKS

S.NO	SOR NO 13-14	DESCRIPTION	UNIT	QNTTY	RATE	AMOUNT
1	1.1	Providing fitting and fixing vitreous water closet squatting pan (Indian type W.C Orissa pattern) with all fittings and fixtures complete including cutting and making good to the walls and floors wherever required. (Flushing Cistern to be paid separately)				
	1.1.1	Indian type W.C Orissa pattern of size 580 x 440 mm				
	(a)	White				
	(i)	Parryware make	nos	4	3,146.98	12,587.92
2	1.2	Providing fitting and fixing vitreous china pedestal type water closet (European type W.C pan 400mm high) with seat and lead ,CP brass hinges and rubber buffers , CI/MS brackets , 40 mm dia flush band with fittings including painting of fittings and brackets, required. (Flushing Cistern to be paid separately)(A) Parryware make (a) White(v)Elite S Trap	nos	1	3,995.51	3,995.51
3	1.5	Supplying, fitting and fixing PVC flushing cistern with all internal fittings with CI brackets including fitting and fixing standard size CP flush pipe, union clamps etc. compete as directed and specified (pipes will be measred separately) (I) Parryware make (a) White (i) Economy Single Flush	nos	5	1,981.73	9,908.65
4	1.7	Providing fitting and fixing vitreous china flat back type lipped front urinal basin of with automatic flushing cistern with standard flush pipe and CP brass spreader andbrass unions, etc. complete including painting of fittings and brackets, cutting and making good the walls & floors wherever required. (A) Parryware make (a) White (ii) Integrated EFS-AC with power source (Cat No.C8097) / Integrated EFS- DC (Cat No.C8098)	nos	5	17,187.71	85,938.55

5	1.11	Supplying fitting and fixing vitreous china division plate including fitting and fixing complete as directed and specified. (i) Parryware Make (a) White (i) Partion Magnum / Large (Cat. No.C0571/07)	Each	5	1,817.26	9,086.30
6	1.9	Providing fitting and fixing vitreous china squatting plate urinal with automatic flushing cistern with standard flush pipe and CP brass spreader andbrass unions, etc. complete including painting of fittings and brackets, cutting and making good the walls & floors wherever required. (A) Parryware Make (i) White (Cat. No. C0503)	Each	5	3,156.68	15,783.40
7	1.13	Providing vitreous China wash basin with CI/MS brackets, C.P brass chain with plug,PVC waste pipe including painting of fittings and brackets, cutting and making good the walls wherever required. (Pillar cock, stop cocks, waste coupling are to be paid separately)				
8	1.13.2	Basin (without pedestal)				
8.1.1		(A) Parryware make(a)White				
8.1.1.1		(i) Star Basin 550 x 400 (Cat. No.C0450)	Each	9	2,256.68	20,310.12
9	1.21	Providing, fitting and fixing soap dish of Parryware make complete as specified and directed. (A) Parryware make				
	(ii)	Wall Soap tray (Cat. No.C9951)	Each	9	314.25	2,828.25
10	1.24	Supplying, fitting and fixing chrome plated C.P. towel rail of Sona make complete as specified and directed.				
	(c)	Parryware make(cat. No. C9948)	Each	9	1,150.65	10,355.85
11	1.27	Providing fitting and fixing robe hook of Jaquar make complete as directed and specified.				
	(i)	Continental (Cat.No. ACN-1191N)	Each	5	447.58	2,237.90
12	1.31	(a)Supplying, fitting and fixing C.P. Toilet paper holder of Jaquar make complete as directed and specified.				
	(i)	Continental toilet paper holder(Cat no. CAN-1151N)	Each	5	780.93	3,904.65
13	1.33	a) Proving fitting and fixing C.P. bottle trap,Jaquar make for basin etc. complete as directed and specified.				
	(i)	Bottle trap 32mm size with 250mm long wall connection pipe (Cat. No.ALD-769)	Each	9	1,356.72	12,210.48

14	1.19	Providing fitting and fixing Decorative Mirror complete as directed and specified.(A)Parryware make(a) 800mx600mm	Each	9	3,417.43	30,756.87
15	1.32	Providing, fitting and fixing Chrome Plated waste coupling complete as directed and specified.(a) Jaquar make(i) 32mm	Each	9	405.16	3,646.44
TOTAL-----A						2,10,962.97
16	1.37.1	Supplying , fitting and fixing PVC pipes of 6 kg/sqcm (Supreme/Prince) or other ISI approved including joining, fitting and fixing with clamp etc. as necessary complete at all levels including below G.L. as directed and specified.				
	(a)	In exposed surface or in trenches				
	(ii)	110 mm dia	R.m	28.82	630.80	18,179.66
17	1.37.4	Supplying fitting and fixing 45 degree PVC bend of Supreme/Prince make including joinining, fitting and fixing etc. as necessary complete at all levels including below G.L as directed .				
	(a)	In exposed surface or in trenches				
	(ii)	110 mm dia	Each	4	192.38	769.52
18	1.37.5	Supplying fitting and fixing P.V.C plain single tee of Supreme/Prince make including joinining, fitting and fixing etc. as necessary complete at all levels including below G.L as directed .				
	(a)	In exposed surface or in trenches				
	(ii)	110 mm dia	Each	4	278.76	1,115.04
19	1.37.6	Supplying fitting and fixing P.V.C single tee with door of Supreme/Prince make including joinining, fitting and fixing etc. as necessary complete at all levels including below G.L as directed .				
	(a)	In exposed surface or in trenches				
	(ii)	110 mm dia	Each	4	354.66	1,418.64
20	1.37.13	Supplying fitting and fixing P.V.C coupler of Supreme/Prince make including joinining, fitting and fixing etc. as necessary complete at all levels including below G.L as directed .				
	(a)	In exposed surface or in trenches				
	(i)	110 mm dia	Each	4	133.49	533.96
21	1.39	Providing fitting and fixing PVC cowel of ISI make complete as directed and specified.(ii) 110mm dia. PVC cowel of ISI make	Each	5	153.12	765.60
22	1.42	Providing, fitting and fixing CP grating to the floor complete as directed.				

	(ii)	110mm dia	Each	15	257.82	3,867.30
TOTAL-----B						26,649.72
GRAND TOTAL-----A+B						2,37,612.69

Estimated cost of WATER SUPPLY WORKS for the proposed *TOILET BLOCK* at *MATHGHARIA, ASSAM* based on Assam PWD Schedule of Rates for Sanitary & Water Supply Works 2013-14.

WATER SUPPLY WORKS

S.NO	SOR NO 13-14	DESCRIPTION	UNIT	QNTT Y	RATE	AMOUNT
1	3.1.6	Supplying fitting and fixing CPVC pipes having thermal stability for hot & cold water supply including all CPVC plain & brass threaded fitting including clamps at 1.0 M spacing. This include joining of pipes & fittings with one step CPVC solvent cement and testing of joints complete at all level as directed and specified.				
	(A)	In exposed surfaces or in trenches.				
	(e)	40 mm dia	R.m	19.25	308.16	5,932.08
1.1	(B)	Concealed by chiselling or breaking brick wall/C.C/RCC and making good the damages.				
	(a)	15 mm dia	R.m	11.00	167.44	1,841.84
	(b)	20 mm dia	R.m	22.00	191.93	4,222.46
	(c)	25 mm dia	R.m	28.00	247.02	6,916.56
2	3.2.1	Supplying fitting and fixing C.P bib cock 15 mm dia of approved brand directed and specified. (pipes will be measured separately)				
	II	Jaquare make				
	(a)	Continental/Clarion(ii) Bibcock long thread	Each	5	812.99	4,064.95
3	3.3.2	Supplying fitting and fixing C.P stop cock 15 mm dia of approved brand directed and specified. (pipes will be measured separately)				
	I	Jaquare make				
3.1	iv	15mm dia	Each	24	929.59	22,310.16
4	3.5.1	Supplying and fitting fixing C.P pillar cock of 15 mm dia of approved brand as specified and directed.				
	(II)	Jaquare make				
	(a)	Continental	Each	9	644.22	5,797.98
5	3.17.1	Supplying and fitting gun metal country pit valve (full way valve) ISI make as specified and directed.				
	(b)	40 mm dia	Each	3	1,858.02	5,574.06

6	5.4.2	Supplying and placing plastic cylindrical vertical claused top (PCVC) tank of Sintex / Polycon / Patton make over the staggging with manhole cover with locking and cleaning arrangement including providing pads of size as required for inlet and outlet pipes				
	(III)	1000 litre capacity				
	(a)	Sintex make	Each	2	7,666.00	15,332.00
DEEP BORING						
7	5.3.4	Labour for boring hole for inserting tube well pipes through different soil/ rock media including hire charges of drill pipes, scaffolding, tools and plants as necessary and taking out the same and lowering pipes, fittings complete as directed by the Department.				
	(vi)	Borehole of 200mm diameter	Rm	85	560.90	47,676.50
8	5.3.5	Supplying, fitting and fixing pipes (plain/ bevel ended) for casing, conforming to relevant IS codes of practice including supplying and fitting of tubewell accessories, lowering of assembly pipes concentrically in the borehole followed by supplying and packing of pea gravel free from dirt, dust and other foreign materials in the annular space between the borehole and assembly pipes complete as directed.				
	(II)	PVC pipe SUPREME/PRINCE/FUSION/SFMC Brand				
	(viii)	200mm diameter	Rm	85	1,891.22	1,60,753.70
9	5.3.6	Supplying, fitting and fixing suction pipes (plain/ bevel ended) conforming to relevant IS codes of practice including supplying and fitting of accessories, lowering of assembly pipes concentrically in the casing pipes complete as directed .				
	(B)	PVC pipe SUPREME/PRINCE/FUSION/SFMC Brand				
	(viii)	160mm diameter	Rm	85	1,297.05	1,10,249.25
10	5.3.9	Supplying fitting and fixing ISI approved PVC filter 3.00 metre long.	Each	1	1,866.25	1,866.25
11	5.3.12	Development of the tubewell/ boring with compressor or by over pumping unit for 48 hours till sand free discharge is obtained.	job	1	14,500.00	14,500.00
12	5.3.13	Flushing, clearing, washing and watering of the tube well.	job	1	3,500.00	3,500.00
13	Electrical 39.3.2	1 HP single Phase Centrifugal monoblock pump set(Crompton Greaves/Aquatic/CRI/V-Guard/Calma make) with DOL Starter(Crompton Greaves/Control & Switch Gear/BCH/L & T/Siemens make)	Each	1	14,096.00	14,096.00

14	water tank(PCVC) 5.4.2	supplying and placing plastic cylindrical vertical closed top (PCVC) tank of Sintex / Polycon / Patton make over the staging with manhole cover with locking and cleaning arrangement including providing pads of size as required for inlet and outlet pipes. (l) 2000 Lt capacity (a) sintex make	Each	1	13,685.00	13,685.00
TOTAL WATER SUPPLY WORK						4,38,318.79